

RADIANTE 692

INSTALLATION & USER MANUAL



**CHEMINÉES
PHILIPPE**
A U S T R A L I A

*“We no longer build fireplaces for physical warmth,
we build them for the warmth of the soul, we build
them to dream by, to hope by, to home by”
- Edna Ferber 1885-1968*

We thank and appreciate your trust in welcoming our Cheminées Philippe Radiante 692 into your space. Living with a Cheminées Philippe is truly a most satisfying and memorably rewarding experience. You have now joined the family of thousands of proud owners of the most beautifully hand crafted fireplaces in the world.

For over six decades Cheminées Philippe have been synonymously known for their quality French design appeal and admirably, their hand made technique. Manufactured in their cast iron foundry located in the Pas-de-Calais region of France, they adhere to strict European requirements, as well as being tested and certified to Australian emissions, efficiency and safety standards.

Please take a moment to read over this manual, including our operations and maintenance guide to ensure you get the best performance and enjoyment from your new fireplace.

We wish you many wonderful years of fireside enjoyment.

Warmest regards,

Rick Wignell

Director of Cheminées Philippe Australia

1. PREFACE	
1.1 NOTICE	04
1.2 GENERAL SAFETY INFORMATION	05
1.3 PRE-INSTALLATION GUIDELINES	06
1.4 GENERAL FLUE REQUIREMENTS	07
1.5 SUITABLE BASE & HEARTH MATERIALS	08
2. UNIT DIMENSIONS & SPECIFICATIONS	
2.1 CHEMINÉES PHILIPPE RADIANTE 692	10
3. FREESTANDING	
3.1 STEP BY STEP INSTALL GUIDE	12
3.2 BASE & HEARTH DIMENSIONS	13
3.3 FREESTANDING CLEARANCES	14 & 15
3.4 SKAMOTEC WALL GUIDELINES	16
3.5 SKAMTOEC WALL VENTILATION	17
3.6 FLUE COMPONENTS OVERVIEW	18
3.7 FLUE SYSTEM CONFIGURATIONS	19
4. INBUILT	
4.1 STEP BY STEP INSTALL GUIDE	22
4.2 BASE, HEARTH & MANTEL SHELF DIMENSIONS	23
4.3 INBUILT SPECIFICATIONS	24
4.4 ALCOVE SPECIFICATIONS	25
4.5 DEFLECTOR PLATE & GRILLS	26
4.6 FLUE COMPONENTS OVERVIEW	27
5. MECHANISMS & UNIT ASSEMBLY	
5.1 MECHANISM GUIDE	30
5.2 PARTS & DAMPER ASSEMBLY	31
5.3 BACK PLATE, BAFFLE PLATE & GRATE ASSEMBLY	32
6. OPERATION	
6.1 BEFORE FIRST IGNITION	34
6.2 RECOMMENDED FIRE WOOD	35
6.3 HOW TO LIGHT & BURN SAFELY	36 & 37
6.4 WARNING LABELS	38
7. MAINTENANCE	
7.1 SERVICING GUIDE	40
7.2 TROUBLE SHOOTING	41
7.3 SPARE PARTS	42
8. WARRANTY	
8.1 WARRANTY POLICY & EXTENDED WARRANTY	44
8.2 INSTALLER CHECKLIST FORM	45

*Please keep these instructions for future reference.

DOCUMENT REVISION 06

This document is valid for Australia & New Zealand as of April 18th 2026 for the installation, operation and maintenance of the *Cheminées Philippe Radiante 692* wood fireplace.

DISCLAIMER

Cheminées Philippe Australia bears no liability for installations that do not meet the criteria outlined in this manual, alongside the requirements of Australian & New Zealand Standards AS/NZS 2918:2018. The installation techniques, handling and use of the product are beyond our control. Therefore, *Cheminées Philippe Australia* assumes no responsibility for loss, damage or expense resulting from improper installation, operation or misuse. In line with our commitment for continuous improvement, technical parameters are subject to change and we reserve the right to alter the contents of this manual at any time. For the latest version of this manual please visit, www.chemphilaust.com.au

MUST READ PRIOR TO COMMENCING

Please read through this manual carefully prior to installing or using this fireplace. Each of our fireplaces should be installed in accordance with AS/NZS 2918:2018, the appropriate requirements of the relevant building codes and this manual. All units **MUST** be installed by a fully licensed and qualified trades professional who is registered and/or licensed in mechanical services with a class also restricted to solid fuel heaters (or equivalent in selected states and territories).

WARRANTY: The warranty of this fireplace is only valid if the unit has been installed as per the above requirements and the installer checklist has been completed (page 45 of this manual). An extended warranty period can also be granted, please see page 44 of this manual for further details on how to apply for an extended warranty.

CUSTOM INSTALLATIONS: Contact us for approval of any deviation from this document prior to proceeding. In the event that an installation is undertaken without following this installation manual or without written approval by *Cheminées Philippe Australia*, then the sole responsibility of any adverse outcomes lies with the installer and the unit will be null and void of all warranties.

WARNING: THE APPLIANCE AND FLUE SYSTEM SHOULD BE INSTALLED IN ACCORDANCE WITH AS/NZS 2918:2018 AND THE APPROPRIATE REQUIREMENTS OF THE RELEVANT BUILDING CODE OR CODES.

WARNING: APPLIANCES INSTALLED IN ACCORDANCE WITH AS/NZS 2918:2018 SHOULD CONFORM TO THE REQUIREMENTS OF AS/NZS 4013 AND AS/NZS 4012 WHERE REQUIRED BY THE REGULATORY AUTHORITY, THAT IS. THE APPLIANCE SHOULD BE IDENTIFIABLE BY A CONFORMANCE PLATE WITH THE MARKING 'TESTED TO AS/NZS 4013 AND AS/NZS 4012' AS SPECIFIED IN AS/NZS 4012.

ANY MODIFICATION OF THE APPLIANCE THAT HAS NOT BEEN APPROVED IN WRITING BY THE TESTING AUTHORITY IS CONSIDERED TO BE IN BREACH OF THE APPROVAL GRANTED FOR CONFORMANCE TO AS/NZS 4013.

CAUTION: MIXING OF APPLIANCE OR FLUE SYSTEM COMPONENTS FROM DIFFERENT SOURCES OR MODIFYING THE DIMENSIONAL SPECIFICATION OF COMPONENTS MAY RESULT IN HAZARDOUS CONDITIONS. WHERE SUCH ACTION IS CONSIDERED THE MANUFACTURER SHOULD BE CONSULTED IN THE FIRST INSTANCE.

CAUTION: CRACKED AND BROKEN COMPONENTS, FOR EXAMPLE GLASS PANELS, CAST IRON OR CERAMIC TILES, MAY RENDER THE INSTALLATION UNSAFE.

PREPARATION OF THE FIREPLACE

- » Before installing this fireplace thoroughly assess the packaging and it's contents (including the unit, flue components, grates, baffle plates, ceiling ring, etc) to ensure all items are accounted for and that any damage or defects caused by transport/handling are immediately reported to your authorised *Cheminées Philippe* dealer
- » Check the installation site in advance and remove all flammable materials or those which have the potential to be damaged by heat from the area where the fireplace will be installed. All combustible material should be replaced and/or shielded with non-combustible material or maintain a safe clearance as per pages 12-19 of this manual if installed freestanding or 22-26 if installed inbuilt
- » Ensure the correct base underneath the fireplace is used including the minimum size and thickness, refer to page 8 for a list of recommended base materials. Check that the floor is capable of safely bearing the weight and if necessary put in a weight distribution plate or take other necessary measures
- » Due to the weight of each fireplace care must be taken when maneuvering the unit. We strongly recommend mechanical equipment, as well as multiple professionals aiding with moving the unit into it's intended location
- » Familiarise yourself with section 5. *Mechanisms & Unit Assembly* in this manual prior to proceeding. Due to the size of some units, the gather, lift door mechanisms, and/or dampers will need to be installed prior to the installation of the flue system. Please also refer to this section for the final fitting of the backplate, baffle plate, ash retainer and grates
- » When installing the unit inbuilt, ventilation grilles are required at the top and bottom of the cavity to assist in natural convection and for the release of heated air into the room. Refer to pages 24-27 for minimum sizes and placement of grilles
- » When installing the fireplace inbuilt, an inspection hatch or trap door is recommended. This will allow for easy access to the unit when performing any necessary inspection, maintenance and/or repairs
- » Do **NOT** use combustible material (including Gyprock Fyrecheck OR a timber frame) within the noncombustible zones
- » **WALL FINISHES:** It is the responsibility of the purchaser and installer to ensure that all finishes (including but not limited to, render, paint, tiles, stone, etc) near and around the fireplace have the capacity to withstand high temperatures. *Cheminées Philippe Australia* cannot be held liable for thermal expansion cracking, blistering or damage of any finishing materials

BALANCING AIR PRESSURE: TIGHTLY SEALED HOMES, MECHANICAL FANS & DOWNDRAFT

All fireplaces require constant air flow when in use, however due to the tightly sealed nature of certain homes it may prove difficult to achieve a continuous replenishment of fresh air for the fire to burn effectively. Mechanical fans (including range hoods, ceiling fans, return air vents including AC ducts, and overhead extractor fans) which are located within the same space as the fireplace, can also create negative pressure and compromise the operation of the unit.

If this occurs, the introduction of fresh air is recommended. This could take the form of a vent installed on an external wall where the fireplace will be situated. Depending on the installation type, it should either be placed directly inside the inbuilt fireplace cavity or as near to the freestanding fireplace as possible. The surface area of this air intake should be a minimum of 360cm² (for example a vent 400mm x 90mm in size).

Termination of the flue in a high pressure zone such as on the downstream side of a nearby obstruction to airflow. For example; trees, hills, adjacent buildings or parts of the building where the unit is installed may also prove to cause downdraught conditions (AS/NZS 2918:2018 extract), in this case refer to page 41.

FLUE SYSTEM

- » Only an approved *Cheminées Philippe* flue kit should be installed with this fireplace
- » Mixing flue system components and/or modifying the dimensional specification of the flue and cowl is NOT recommended, unless approved by *Cheminées Philippe Australia*
- » A **minimum 4.5 metres** of flue is required from the top of the fireplace gather to the cowl
- » A minimum 920mm clearance is to be maintained around the single skin flue to any combustibile surface
- » A minimum 285mm clearance is to be maintained around the outer casing of the double skin flue to any combustibile surface
- » A minimum 50mm clearance is to be maintained around the outer casing of the triple skin flue to any combustibile surface

FLUE BENDS

- » Do **NOT** install bends directly on top of the fireplace gather. A minimum 900mm length of flue must be installed first before the first bend is positioned
- » No more than 4 x 45 degree bends are allowed. The length of flue between two bends must not exceed 1800mm. For each set of bends an extra length of flue should be added. Additional vertical flue may be required to further assist with adequate draw
- » 90 degree bends are **NOT** to be used

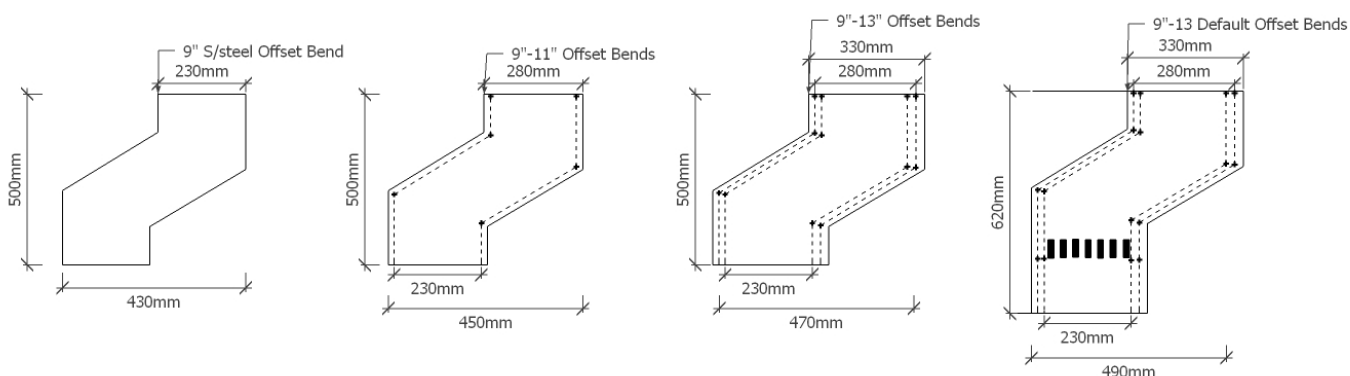

MINIMUM EXTERNAL FLUE HEIGHTS & COWL CLEARANCES - AS PER AS/NZS 2918:2018

*All dimensions in mm

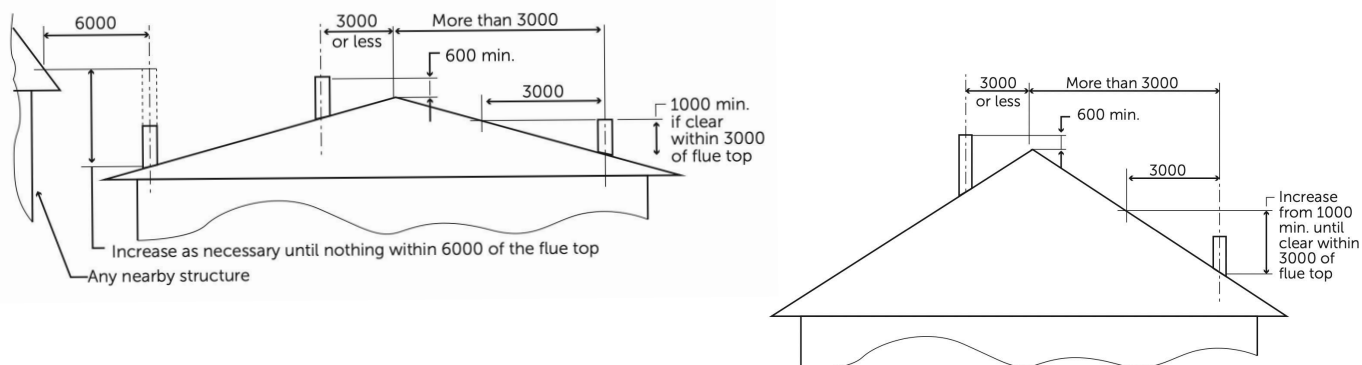

RECOMMENDED FIREPLACE BASE

- » A minimum 150mm hebel, masonry or clay bricks
- » A steel bench with any of the above materials installed beneath it
- » A *CHP 692 Universal steel bench* placed directly onto a combustible floor (no floor protection required) Minimum size 1000mm (w) x 900mm (d) x 200mm (h). Must have a 300mm forward projection in front of the fuel loading door.
- » A suspended 100mm thick solid and supported concrete plinth. A minimum 200mm air gap must be maintained from the underside of the concrete plinth to any combustible surface beneath it
- » *For minimum base size refer to page 13 for freestanding or 23 for inbuilt application*

UNIT LEVELING: Depending on the type of base used underneath the fireplace, it maybe necessary to level and stabilise the unit by using packers underneath for additional support. We recommend using a strip of lead sheet folded over three times.

RECOMMENDED FIREPLACE HEARTH (FLOOR PROTECTION)

- » A minimum 36mm thick cement sheet is required or a composition of masonry materials at this thickness or greater
- » If using the *Cheminées Philippe 692 Universal* steel bench a hearth on the floor is not required
- » *For minimum hearth size refer to page 13 for freestanding or 23 for inbuilt application*

IMPORTANT: Please note that *Cheminées Philippe Australia and Wignells of Melbourne* can not be held liable for any thermal expansion cracking of the materials listed above OR for any other type of masonry material (including tiles and stone) used for the fireplace base and hearth.

The purchaser should check with the base and hearth supplier that the material being used underneath and in front of the fireplace is suitable for extreme heat. The base and hearth should be a heat resistant material with an allowable surface temperature of 600°C degrees or greater.

All fireplace base and hearth materials mentioned above are recommended for their thermal properties only. It is the responsibility of the purchaser and the installer to ensure that any material used has the structural integrity to evenly support the fireplace weight (refer to page 10) and flue componentry.

- » A *Cheminées Philippe* base shield can be used to help prevent heat transfer from the underside of the unit to the base materials beneath it. This is a preventative measure only and does not guarantee that damage to the base will not occur.

DO NOT USE

- » Engineered or composite stone
- » Skamotec board as the fireplace base
- » Thin pre - cast concrete
- » Timber or any combustible material
- » Glass

2. UNIT DIMENSIONS & SPECIFICATIONS

2.1 CHEMINÉES PHILIPPE RADIANTE 692

10

PLEASE NOTE:

Due to the handmade nature of our fireplaces there may be a slight variance factor of 1-2mm across all unit dimensions and .5kg in unit weight.

UNIT SPECIFICATIONS & DIMENSIONS

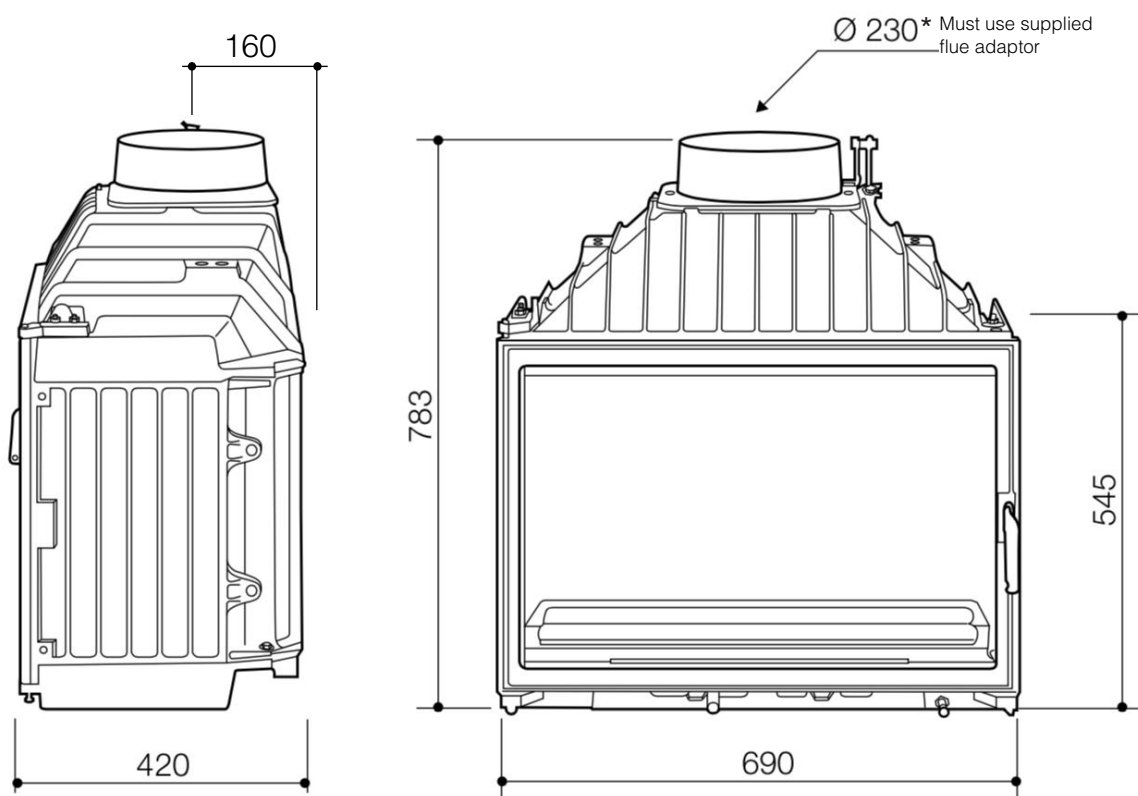

HEATING CAPACITY	Up to 220sqm*
MAXIMUM AVG. HEAT OUTPUT	14.6kW
FIREBOX MATERIAL	Cast Iron
LOG LENGTH	Up to 50cm
FLUE SIZE*	9", 11" & 13"
RECOMMENDED MINIMUM FLUE HEIGHT	4.5m Metres (From top of spigot)
FIREBOX WEIGHT	146kg
OVERALL AVG. EFFICIENCY	63%
PARTICULATE EMISSIONS FACTOR	0.9g/kg
TEST REPORTS	ASFT19020-1 ASFT19075-1 ASFT25111-1
CERTIFICATE OF COMPLIANCE	#ASFT19C013

*Heating output varies depending upon ceiling height, fuel used, building insulation, geographical zone and atmospheric conditions. This unit has been tested and complies with Australian & New Zealand standards AS/NZS 4012 (2014), AS/NZS 4013 (2014) & AS/NZS2918 (2018), and is recommended to be used with hardwood only.

3. FREESTANDING	
3.1 STEP BY STEP INSTALL GUIDE	12
3.2 BASE & HEARTH DIMENSIONS	13
3.3 FREESTANDING CLEARANCES	14 & 5
3.4 SKAMOTEC WALL GUIDELINES	16
3.5 SKAMTOEC WALL VENTILATION	17
3.6 FLUE COMPONENTS OVERVIEW	18
3.7 FLUE SYSTEM CONFIGURATIONS	19

PLEASE NOTE:

All diagrams in this manual are for illustration purposes only, DO NOT scale from any of these diagrams. All measurements are in millimetres unless otherwise stated.

STEP 1: INSPECT THE FIREPLACE & FLUE PENETRATION THEN LAY BASE & HEARTH

- » Inspect the area to ensure the fireplace and flue, including clearances, base and hearth, will be installed safely and conform to Australian & New Zealand Standards AS/NZS 2918:2018 and the guides in this manual relative to your type of installation
- » Lay the base and hearth, refer to pages 8 & 13 for minimum sizes and requirements
- » Additional reinforcement may need to be installed in order to support the weight as outlined on page 8

STEP 2: INSTALL WALL PROTECTION

- » If the wall materials are combustible and do not fall within the minimum safety clearances as listed on page 14-15, then additional wall protection must be installed
- » Protection can include materials such as bricks/hebel, Skamotec board or *Cheminées Philippes* steel heat shield/s
- » In the event that the rear base/hearth does not form an abutment with the rear wall, ensure the wall protection extends from the floor to the recommended minimum height requirement
- » When installing Skamotec please refer to pages 14-17 of this manual for minimum clearances and installation process

STEP 3: PUT UNIT INTO POSITION & ASSEMBLE THE DAMPER SYSTEM

- » Due to the weight of this fireplace please take care when putting the unit into position
- » It is at this stage that we highly recommend fitting the damper system (prior to fitting the flue), please refer to page 31 of this manual

STEP 4: INSTALL THE STARTING COLLAR & FLUE

- » The flue adaptor must be fitted into the cast iron collar of the firebox gather
- » When using a single skin flue kit, ensure the flue is installed crimped end down into the flue adaptor
- » When using a double skin flue kit, use the starter flue section into the flue adaptor
- » When using a triple skin flue kit, use the starter flue section into the flue adaptor
- » Secure the flue to the adaptor using 3 stainless steel rivets evenly spaced
- » All stainless steel inner flues (including charcoal painted stainless steel flues) must be joined using stainless steel pop rivets and must be installed crimp end DOWN
- » All galvanised second and third outer casing must be installed crimp end UP
- » The minimum clearance from a single skin flue to any combustible material is 920mm
- » The minimum clearance to the outer double skin flue to any combustible material is 285mm
- » The minimum clearance to the outer triple skin flue to any combustible material is 50mm
- » Refer to page 7 flue requirements and 18 for flue components and overview

STEP 5: TRIPLE SKIN DROPPER & COWL

- » Install non-combustible board to the ceiling if required (refer to page 14)
- » The triple skin dropper box must be installed to a minimum of 150mm below the ceiling with a 50mm clearance maintained around the outer skin
- » At the termination height of the triple skin flue, the active stainless steel inner must be a maximum of 30mm higher than the middle and outer galvanised casing. The stainless steel skirt is screwed to the crimp of the outer casing. The stainless steel cowl slides into the neck of the skirt and must locate inside the active flue below. No fixing is to be done to the cowl
- » Silicone seal the groove seam on the flues outer skin, between the roof flashing and the cowl to prevent ingress of water
- » Refer to section 4.6 in AS/NZS 2918:2018 for installing flue penetrations
- » Please also use the diagram on page 7 to ensure external flue heights and cowl clearances are maintained

STEP 6: FIT THE BACK PLATE, BAFFLE PLATE, ASH RETAINER, GRATES & ASH PAN

- » Ensure the backplate is installed first, then using a log to hold the back plate into position to prevent it from falling, then install the baffle plate
- » Further instructions and assembly instructions can be viewed on pages 30-32 of this manual

STEP 7: TEST FIRE DRAW

- » Light a small piece of newspaper inside the firebox to test the draw of the unit and flue
- » If the draw is inadequate please refer to the Trouble Shooting on page 41
- » If the draw is adequate, complete the check list on page 45 and return this as well as this entire booklet to the fireplace owner

HEARTH REQUIREMENTS

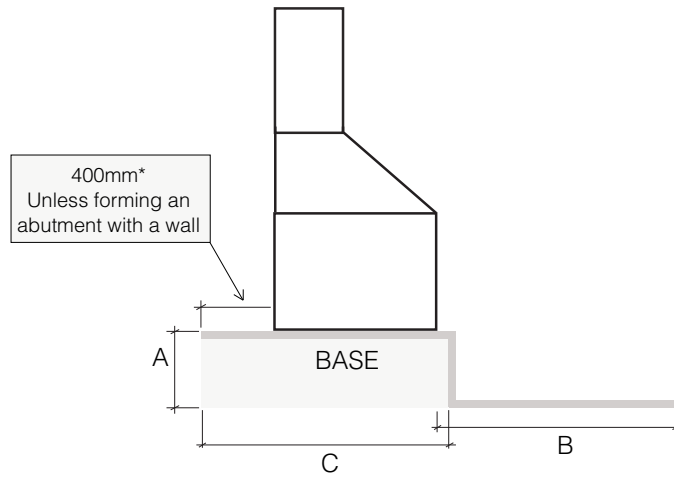

MINIMUM HEIGHT OF UNIT	A. <150mm	A. 150mm	A. 200mm	A. 300mm	A. 400mm	A. 500mm≥
MINIMUM HEARTH DEPTH	B. 1000mm*	B. 600mm	B. 579mm	B. 521mm	B. 433mm	B. 300mm

MINIMUM BASE SIZE: WIDTH: 710mm x DEPTH: As per above (C) x THICKNESS: Refer to page 8**

MINIMUM HEARTH SIZE: WIDTH:1510mm x DEPTH: As per above (B) x THICKNESS: 36mm**

The unit must be placed centrally within the 1510mm width hearth.

**When the unit is raised 149mm or less from floor level, a minimum 1000mm hearth is required beyond all four sides of the unit unless forming an abutment with a wall.*

The base and hearth shall be constructed in accordance with AS/NZS 2918:2018.

ALTERNATIVE RAISED HEARTH

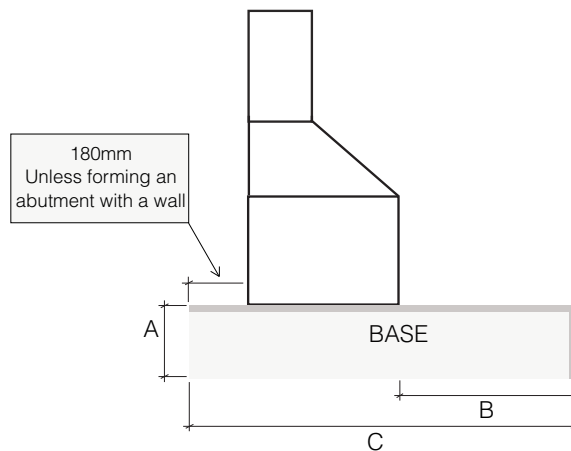

MINIMUM HEIGHT OF UNIT **A.**200mm≥

MINIMUM HEARTH DEPTH **B.**300mm*

MINIMUM BASE SIZE: WIDTH: 710mm x DEPTH: As per above (C) x THICKNESS: Refer to page 8**

MINIMUM HEARTH SIZE: WIDTH:1000mm x DEPTH: As per above (B) x THICKNESS: 36mm**

The unit must be placed centrally within the 1000mm width hearth.

**When using the alternative raised hearth application the unit and hearth must be raised a minimum of 200mm above the floor level.*

The unit must also be placed centrally within the 1000mm width.

IMPORTANT: Unless forming an abutment with a wall, the back and side hearth sizes **MUST NOT** be altered, please refer to page 14 & 15 for minimum sizes.**For a list of recommended materials and thicknesses refer to page 8.

692 HEATSHIELD CLEARANCES TO COMBUSTIBLES

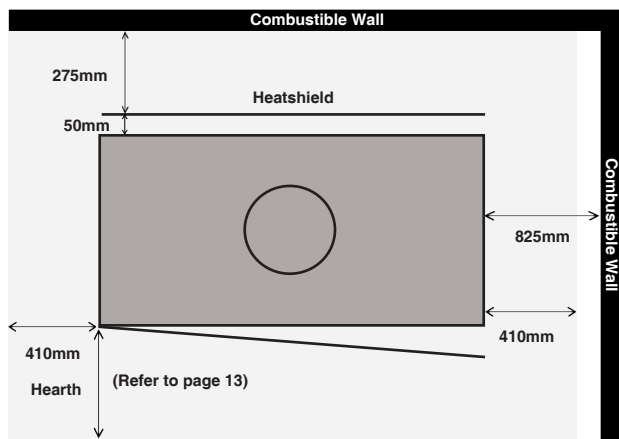

CLEARANCES TO COMBUSTIBLES

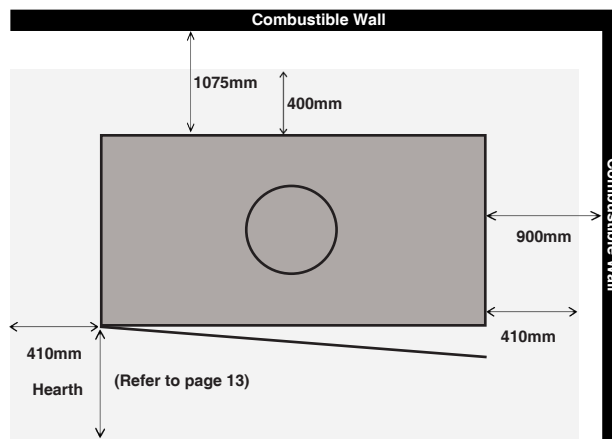

UNIT GLASS CLEARANCE: A minimum 1200mm from the front glass of the unit to any combustible surfaces must be maintained.

COMBUSTIBLE MATERIALS: Mirrors, windows and all other types of glass are also deemed combustible.

HEARTH: All hearth dimensions on this page refer to the unit being raised 150mm or greater above floor level when using the standard hearth requirements, refer to page 13.

STEEL HEAT SHIELD: Closer clearances to combustible materials can be achieved with the use of a custom rear and/or side heat shield option. Refer to the separate heat shield specification sheet.

A: CLEARANCES TO 50MM SKAMOTEC BOARD

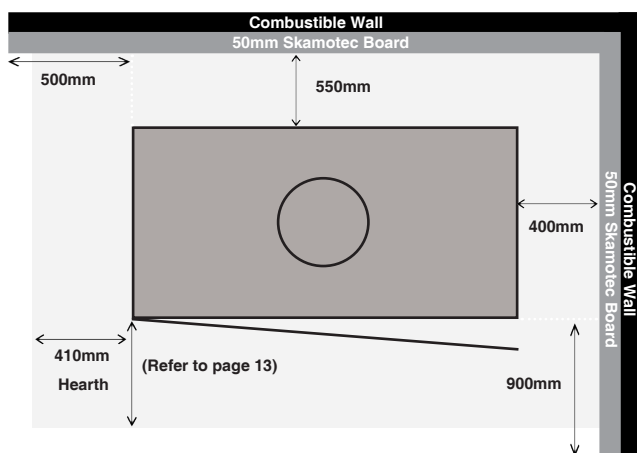

B: CLEARANCES TO 50MM SKAMOTEC BOARD + AIR GAP

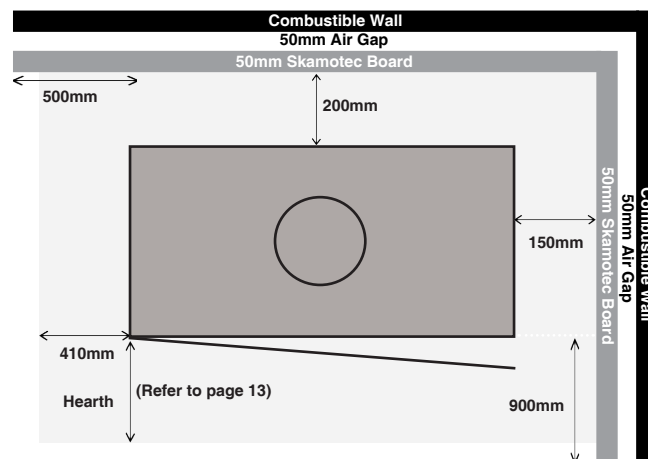

The Skamotec boards should extend to a minimum height of 2000mm from the base when using a double skin flue kit OR all the way to the ceiling when using a single skin flue kit (refer to page 18). When using Skamotec board with a 50mm air gap behind, it must also be ventilated for natural air flow circulation, (refer to page 16 & 17 for ventilation requirements).

CLEARANCES TO SOLID 110MM BRICK

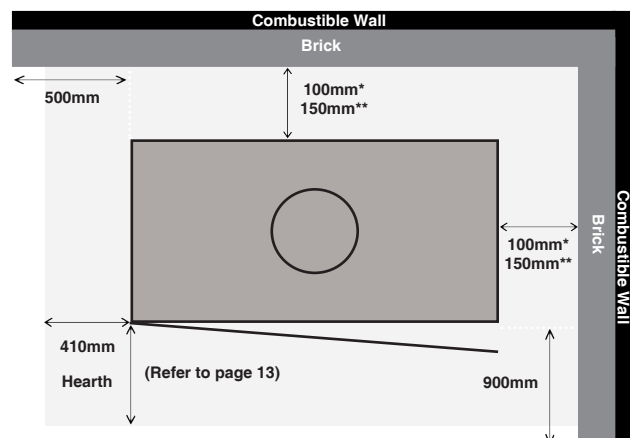

CLEARANCES TO 75MM HEBEL POWER PANELS

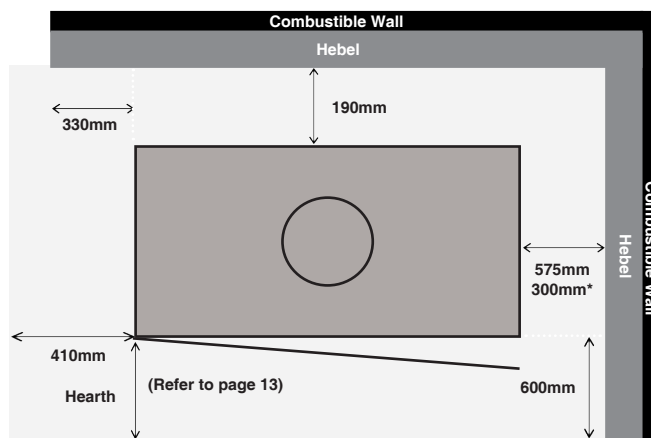

*110 Solid Brick (with minimum 25 airgap to a combustible wall)

**110 Solid Brick (applied directly to a combustible wall)

A minimum 110mm thick solid brick wall should extend a minimum height of 2000mm from the base when using a double skin flue kit or to the ceiling when using a single skin flue kit (refer to page 18).

A 75mm hebel power panel rear and side wall should extend to a minimum height of 1350mm from the base when using a double skin flue kit or all the way to the ceiling when using a single skin flue kit.

***300mm side clearance can be achieved when the 75mm hebel power panel wall extends to a minimum height of 1650mm from the base when using a double skin flue kit or all the way to the ceiling when using a single skin flue kit.**

CORNER CLEARANCES

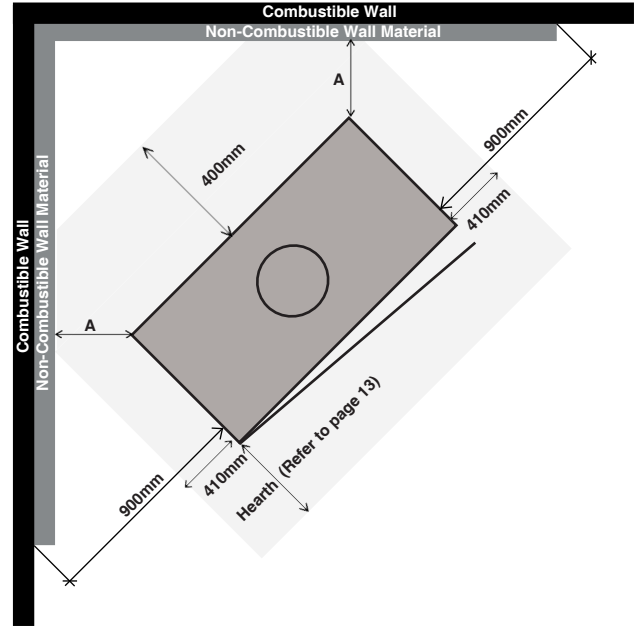
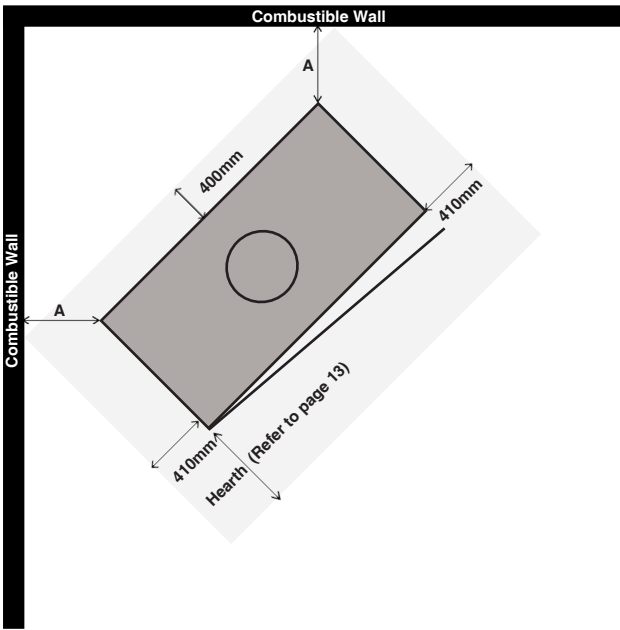

IMPORTANT: All hearth dimensions on this page refer to the unit being raised 150mm or greater above floor level, refer to page 13

WALL MATERIAL	A
COMBUSTIBLE WALL	1075mm
SKAMOTEC BOARD (applied directly to combustible wall)	550mm
50MM SKAMOTEC BOARD + 50MM AIR GAP	200mm
110MM SOLID BRICK (applied directly to combustible wall)	150mm
110MM SOLID BRICK + 25MM AIR GAP	100mm
75MM HEBEL POWER PANEL (applied directly to combustible wall)	190mm

IMPORTANT:

When the unit is positioned on a 45 degree angle into a corner the non-combustible side wall material must extend from the internal corner to a minimum 900mm from the side of the unit.

WALL MATERIAL REQUIREMENTS

SKAMOTEC

The Skamotec boards should extend to a minimum height of 2000mm from the base when using a double skin flue kit OR all the way to the ceiling when using a single skin flue kit (refer to page 18). When using Skamotec board with a 50mm air gap behind, it must also be ventilated for natural air flow circulation, (refer to page 16 & 17 for ventilation requirements).

SOLID 110MM BRICK

A minimum 110mm thick solid brick wall should extend a minimum height of 2000mm from the base when using a double skin flue kit or to the ceiling when using a single skin flue kit (refer to page 18).

75MM HEBEL POWER PANEL

A minimum 75mm hebel power panel wall should extend to a minimum height of 1350mm from the base when using a double skin flue kit OR all the way to the ceiling when using a single skin flue kit (refer to page 18).

SKAMOTEC 225

Also known as “Skamol” board, Skamotec is a lightweight non-combustible board that simplifies the construction process to one building material, therefore eliminating the need for a steel or brick frame construction. It is intended for interior, non-load bearing wall applications and has a maximum service temperature of 1000 degrees celsius

RECOMMENDED FIXING OF SKAMOTEC BOARDS & BATTENS

- » Materials required include construction screws and Skamotec adhesive glue. Please refer to the Skamotec Installers Guide for a comprehensive list of materials, as well as the assembly instructions
- » It is recommended that the 50mm thick Skamotec battens are spaced to a maximum of 450mm centres, be a minimum 100mm wide and are placed vertically behind the board as illustrated below
- » When using 100mm x 50mm Skamotec battens behind the Skamotec board, the cavity must be either ventilated at the top and bottom by using a minimum 25mm air gap that must extend the full width of the board, or alternatively using metal vents (vermin proof if on an external wall) a minimum surface area of 720cm² or 2 x 360cm² at the top and bottom (as illustrated on page 17) can be used
- » Please ensure Skamotec sheets are laid horizontally across the entire width of the fireplace with no vertical joints
- » All corner and panel joints shall be attached using Skamotec mortar cement or construction adhesive
- » Do not fasten any part of the Skamotec board to the fireplace

SKAMOTEC FINISH

- » When applying any adhesive, mortar cement, drywall compound, paint, skim-coat or a scratch coat, all joining surfaces must be cleaned and moistened with water beforehand (Skamotec branded products are recommended). This will prevent these products from drying out too quickly & adhering incorrectly. A painted finish, stone or tile material can be used to finish the Skamotec surface. For a comprehensive Skamotec install and finish, please only refer to the Skamotec 225 Installers Guide

SKAMOTEC COMPOSITION - PLAN VIEW

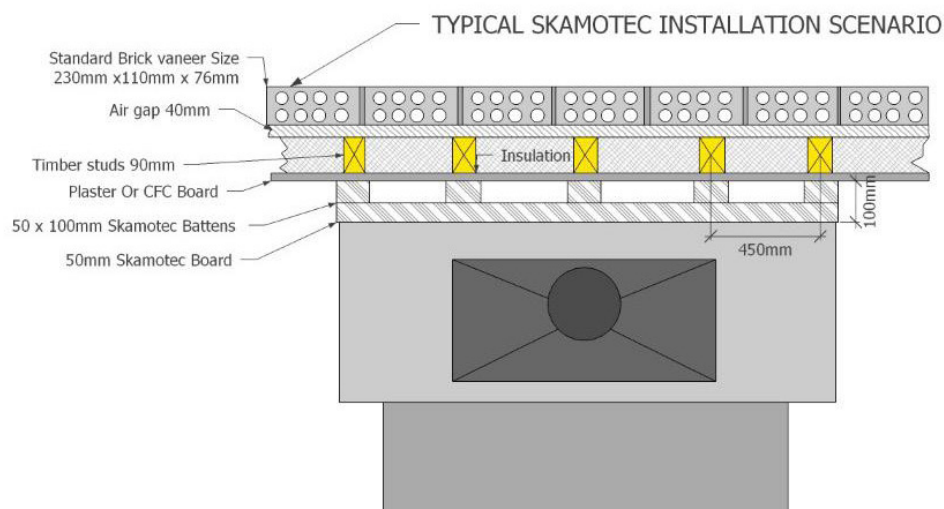

OPTION A: 25MM TOP & BOTTOM AIR GAP

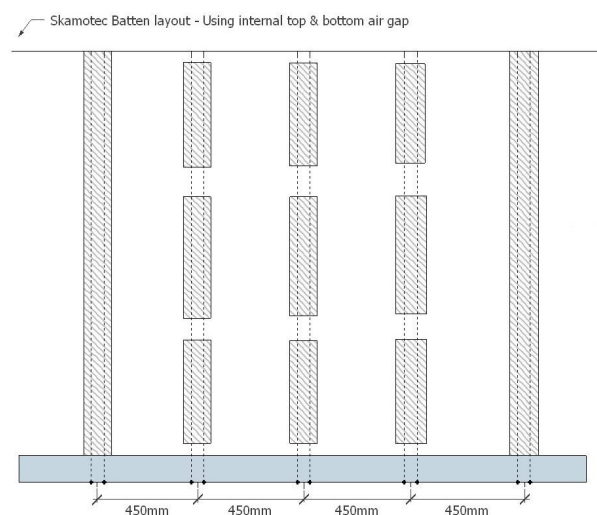
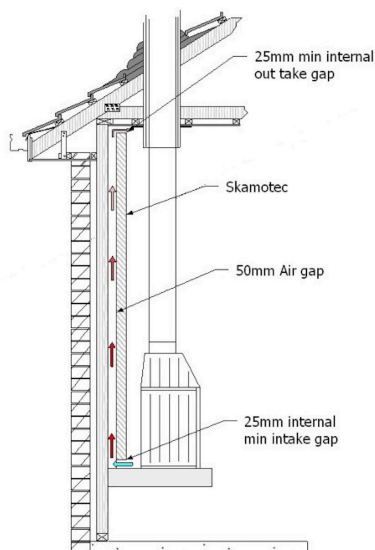

The 25mm top and bottom air gap must extend the full width of the Skamotec cavity and can be left open to create a shadow line effect, or alternatively can be faced with a metal grill/vent

OPTION B: CONCEALED EXTERNAL VENTS

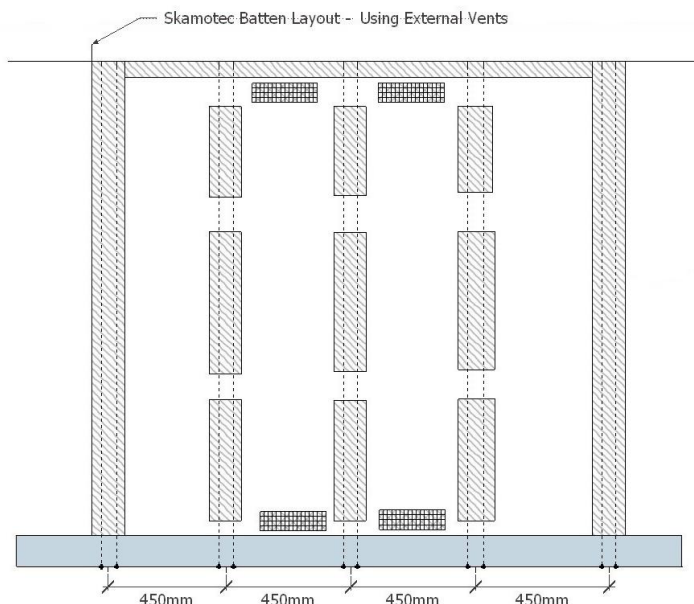
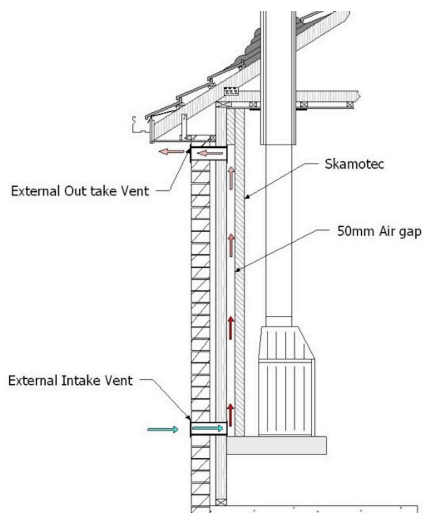

OPTION C: CONCEALED INTERNAL VENTS

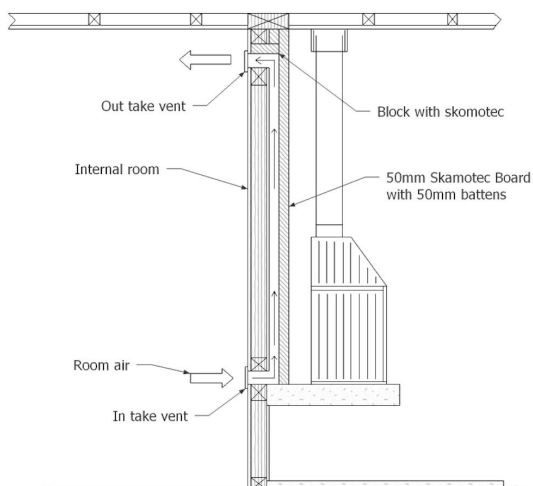

The minimum concealed surface area of vent is one 720cm² top (9cm x 80cm) at the top and bottom or 2 x 360cm² (9cm x 40cm) top and bottom as illustrated

MINIMUM FREESTANDING FLUE KIT COMPONENTS

4.5 METRE 9" SINGLE SKIN FLUE KIT

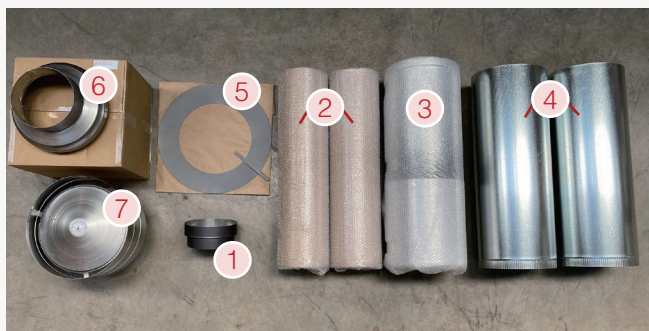

- 1 9" Flue Adaptor* (Painted)
- 2 2 x 9" Single Skin Flue 900mm* (Painted)
- 3 9"-11"-13" Default Triple Skin Flue 900mm* (Painted)
- 4 2 x 9"-11"-13" Triple Skin Flue 900mm*
- 5 13" Split Ring (Painted)
- 6 9"-13" Cover Cone
- 7 9" Anti Down Draught Cowl

4.5 METRE 9" DOUBLE SKIN FLUE KIT



- 1 9" Flue Adaptor* (Painted)
- 2 2 x 9"-11" Double Skin Flue 900mm* (Painted)
- 3 9"-11"-13" Default Triple Skin Flue 900mm* (Painted)
- 4 2 x 9"-11"-13" Triple Skin Flue 900mm*
- 5 13" Split Ring (Painted)
- 6 9"-13" Cover Cone
- 7 9" Anti Down Draught Cowl

*All internal 9" flue must be stainless steel

FREESTANDING INSTALL OVERVIEW*

*SINGLE SKIN FLUE KIT ILLUSTRATION

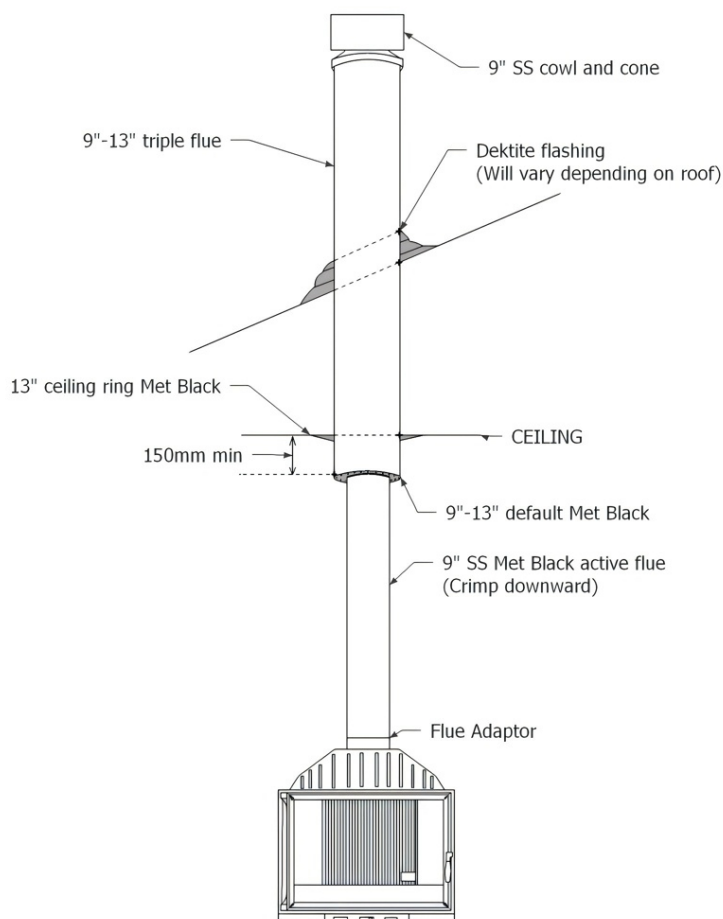

FREESTANDING FLUE CONFIGURATIONS

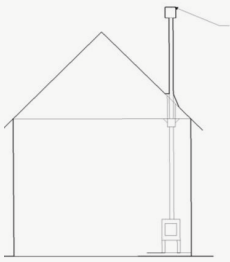

1. Flat ceiling with roof space

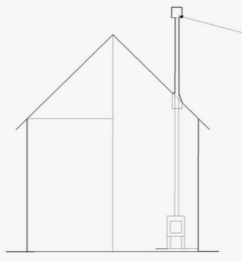

2. Cathedral ceiling

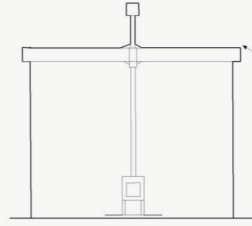

3. Flat ceiling & flat roof

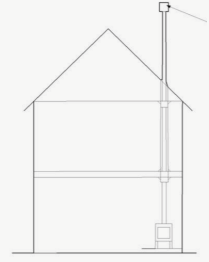

4. Multi floor with flat ceiling and roof space

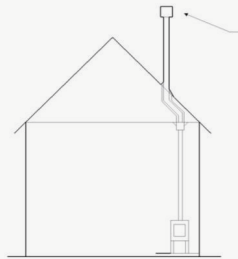

5. Flat ceiling with roof space and offset

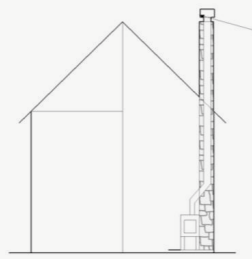

6. Freestanding with chimney & offset

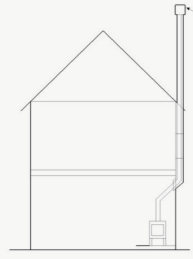

7. External wall penetration

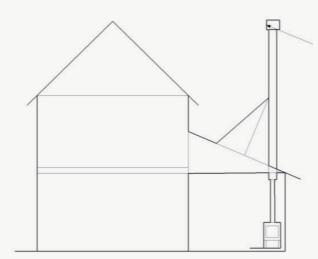

8. Double storey with single storey penetration

Some of these flue scenarios may require additional flue components other than those listed on page 18

NOTES

4. INBUILT	
4.1 STEP BY STEP INSTALL GUIDE	22
4.2 BASE, HEARTH & MANTEL SHELF DIMENSIONS	23
4.3 INBUILT SPECIFICATIONS	24
4.4 ALCOVE SPECIFICATIONS	25
4.5 DEFLECTOR PLATE & GRILLS	26
4.6 FLUE COMPONENTS OVERVIEW	27

PLEASE NOTE:

All diagrams in this manual are for illustration purposes only, DO NOT scale from any of these diagrams. All measurements are in millimetres unless otherwise stated.

STEP 1: INSPECT THE FIREPLACE & FLUE PENETRATION THEN LAY BASE & HEARTH

- » Inspect the area to ensure the fireplace and flue, including clearances, base and hearth, will be installed safely and conform to Australian & New Zealand Standards AS/NZS 2918:2018 and the guides in this manual relative to your type of installation
- » Lay the base and hearth, refer to pages 8, 23 & 24 for minimum sizes and requirements
- » Additional reinforcement may need to be installed in order to support the weight as outlined on page 8

STEP 2: INSTALL BACK & SIDE WALLS

- » Ensure the back and side wall are installed using materials such as brick or hebel, refer to page 24
- » Ensure provisions are made for the bottom air inlets and top air outlet on the cavity, please refer to page 24-25 for minimum sizing, metal vents are to be used

STEP 3: PUT UNIT IN POSITION & ASSEMBLE THE DAMPER SYSTEM

- » Due to the weight of this fireplace please take care when putting the unit into position
- » It is at this stage that we highly recommend fitting the damper system (prior to fitting the flue), please refer to page 31 of this manual

STEP 4: INSTALL THE STARTING COLLAR, FLUE & DEFLECTOR PLATE

- » The flue adaptor must be fitted into the cast iron collar of the firebox gasket
- » Secure the flue to the adaptor using 3 stainless steel rivets evenly spaced
- » All stainless steel inner flues must be joined using stainless steel pop rivets and must be installed crimp end DOWN
- » Determine the height of deflector plate. Cut the starter flue to support the deflector plate at the desired height, refer to page 24 for more details
- » Install the deflector plate on the top of the starter flue gaskets
- » Place rockwool blanket (aluminium side down) on top of the deflector plate ensuring complete coverage. Ensure the rockwool blanket is installed firmly to the inner sides of the enclosure and around the triple skin flue. Ensure the slots of the starter triple are approx 100mm above the top of the rockwool
- » The starter triple (with slots and cap) is then placed on top of the deflector plate
- » All galvanised second and third skins must be installed crimp end UP
- » Pick up weight of outer casing in roof space. The weight of the casing must not be supported by the gaskets alone
- » Minimum clearance to triple skin flue to any combustible material is 50mm
- » At the termination height of the triple skin flue, the active stainless steel inner must be a maximum of 30mm higher than the middle and outer galvanised casing. The stainless steel skirt is screwed to the crimp of the outer casing. The stainless steel cowl slides into the neck of the skirt and must locate inside the active flue below. No fixing is to be done to the cowl
- » Silicone seal the groove seam on the flues outer skin, between the roof flashing and the cowl to prevent ingress of water
- » Refer to section 4.6 in AS/NZS 2918:2018 for installing flue penetrations
- » Please also use the diagram on page 7 to ensure external flue heights and cowl clearances are maintained, also refer to page 27 for flue components overview

STEP 5: FINISH FACADE OF CAVITY

- » Complete the front of the fireplace facade, ensure a minimum clearance of 10mm between the finished fireplace opening and any part of the firebox including any mesh grills attached to it

STEP 6: FIT BACK PLATE, BAFFLE PLATE, ASH RETAINER, GRATES & ASHPAN

- » Ensure the backplate is installed first, then using a log to hold the plate into position to keep it from falling, install the baffle plate.
- » Further instructions and assembly instructions can be viewed on pages 30-32 of this manual

STEP 7: TEST FIRE DRAW

- » Light a small piece of newspaper inside the firebox to test the draw of the unit and flue
- » If the draw is inadequate please refer to the Trouble Shooting on page 41
- » If the draw is adequate, complete the check list on page 45 and return this as well as this entire booklet to the fireplace owner

HEARTH REQUIREMENTS

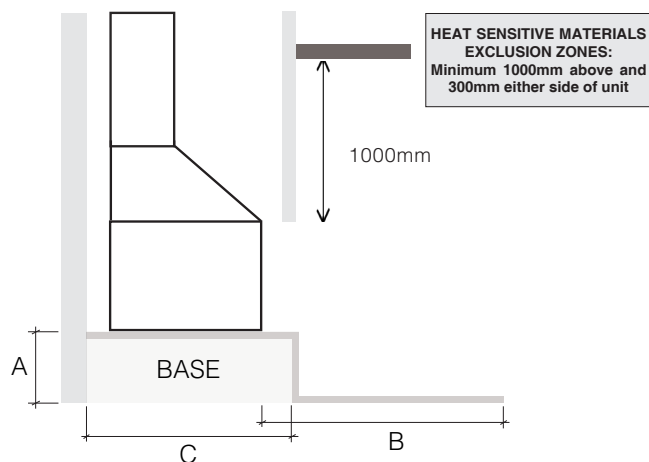

MINIMUM HEIGHT OF UNIT	A. <150mm	A. 150mm	A. 200mm	A. 300mm	A. 400mm	A. 500mm≥
MINIMUM HEARTH DEPTH	B. 1000mm*	B. 600mm	B. 579mm	B. 521mm	B. 433mm	B. 300mm

MINIMUM BASE SIZE: WIDTH: 710mm x DEPTH: As per above (C) x THICKNESS: Refer to page 8**

MINIMUM HEARTH SIZE: WIDTH:1090mm x DEPTH: As per above(B) x THICKNESS: 36mm**

The unit must be placed centrally within the 1090mm width hearth.

**When the unit is raised 149mm or less from floor level, a minimum 1000mm hearth is required forward of the fuel loading door and must extend not less than 200mm on either side of the unit.
The base and hearth shall be constructed in accordance with AS/NZS 2918:2018*

ALTERNATIVE RAISED HEARTH

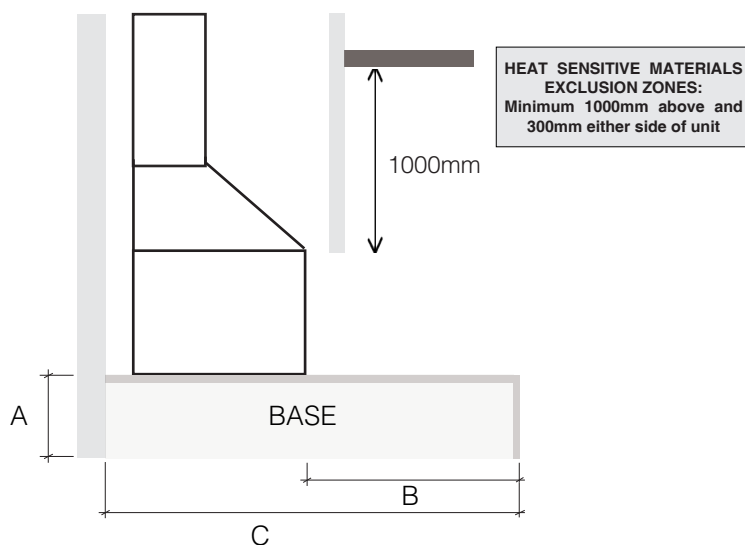

MINIMUM HEIGHT OF UNIT **A.**200mm≥

MINIMUM HEARTH DEPTH **B.**300mm*

MINIMUM BASE SIZE: WIDTH: 710mm x DEPTH: As per above (C) x THICKNESS: Refer to page 8**

MINIMUM HEARTH SIZE: WIDTH:1090mm x DEPTH: As per above(B) x THICKNESS: 36mm**

The unit must be placed centrally within the 1090mm width hearth.

**When using the alternative raised hearth application the unit and hearth must be raised a minimum of 200mm above the floor level. The unit must also be placed centrally within the 1090mm width.*

IMPORTANT: Unless forming an abutment with a wall the width of the hearth MUST NOT be altered.

**For a list of recommended materials and thicknesses refer to page 8.

MATERIALS & CLEARANCES:

INBUILT CAVITY: Use a minimum 110mm solid brick or 100mm hebel with a minimum clearance of 100mm to the back of the unit and 200mm on either side.

EXISTING MASONRY CHIMNEY: When 200mm side clearance can't be achieved then it is recommended to use optional metal vent attachments that are fixed to either side of the unit to assist with adequate air flow. In this case, a minimum 100mm air gap on the back and sides is recommended.

AIR INLET AND OUTLET GRILLES:

Intake Size: A minimum surface area of 360cm² is required for air intake on either side of the bottom of the cavity, (minimum size grilles 9cm x 40cm) and should be in line with the base of the fireplace.

Outtake Size: The same size on either side is required for the top air outtake on either side OR one long outtake grill can be installed at the front of the cavity (directly below the internal deflector plate) creating a minimum of 720cm² in total size (minimum size vent 9cm x 80cm).

All dimensions are in millimetres.

PLAN VIEW

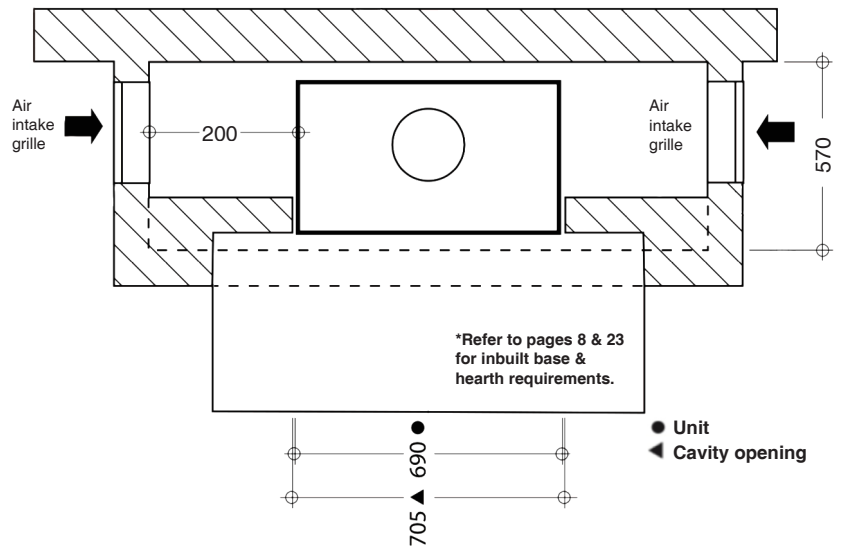

SIDE VIEW

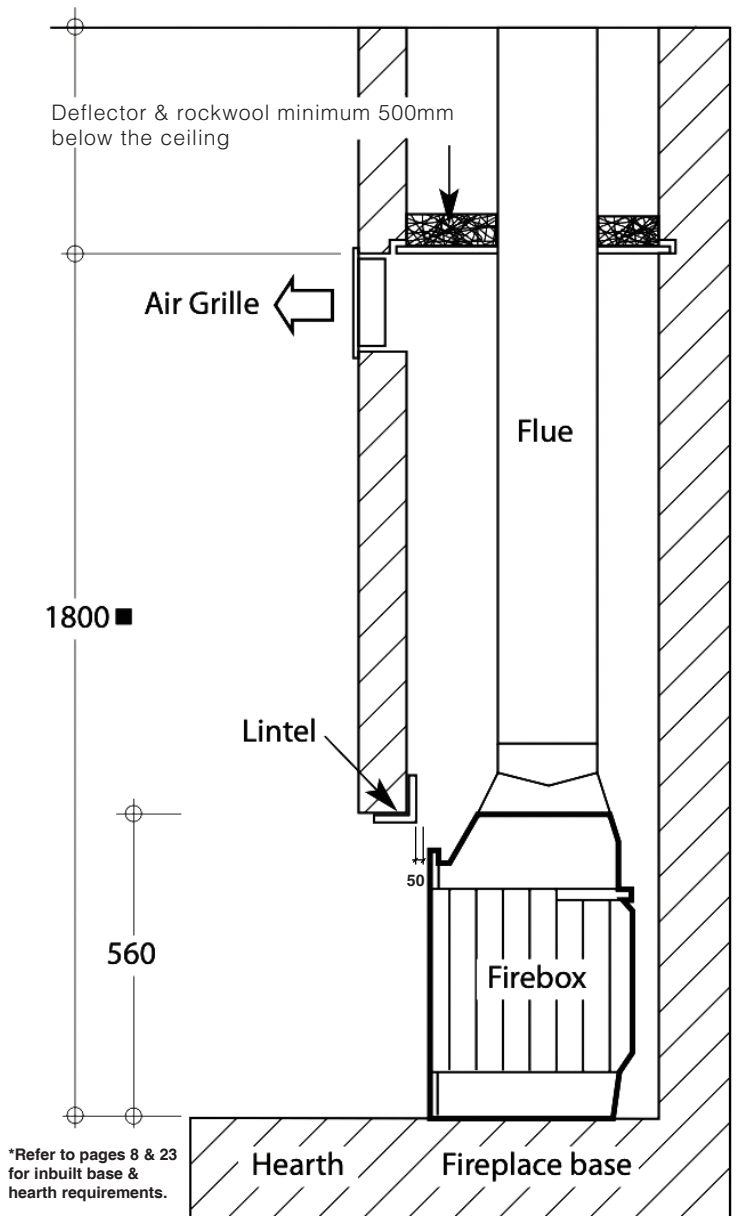

FIREPLACE CONSTRUCTION STEP 2

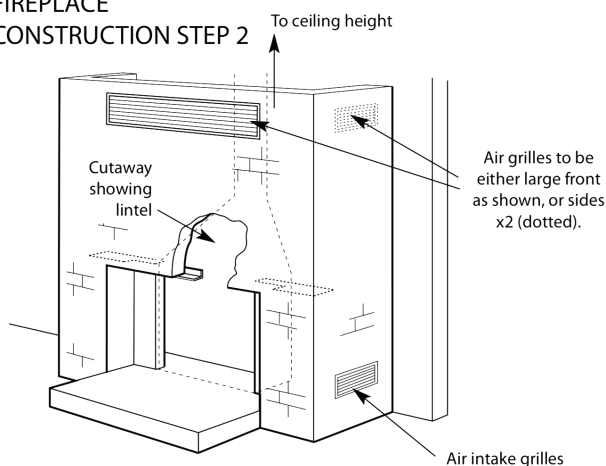

MATERIALS & CLEARANCES:

Refer to Freestanding Clearances to solid 110mm brick on page 14.

ALCOVE: When the facade is completely open, the use of a ventilation grill is not required.

ALCOVE WITH APRON: When the facade is partially open, an outlet grill is required. Refer to the diagram below.

AIR OUTLET GRILLES:

Outtake Size: Refer to page 24.

All dimensions are in millimetres.

PLAN VIEW

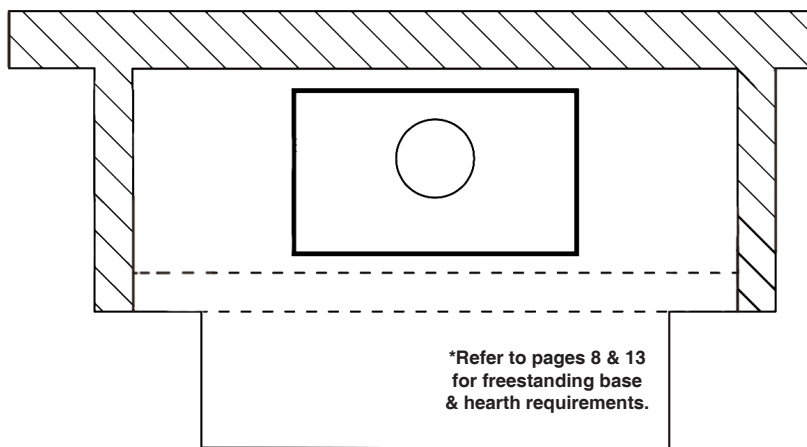

ALCOVE - SIDE VIEW

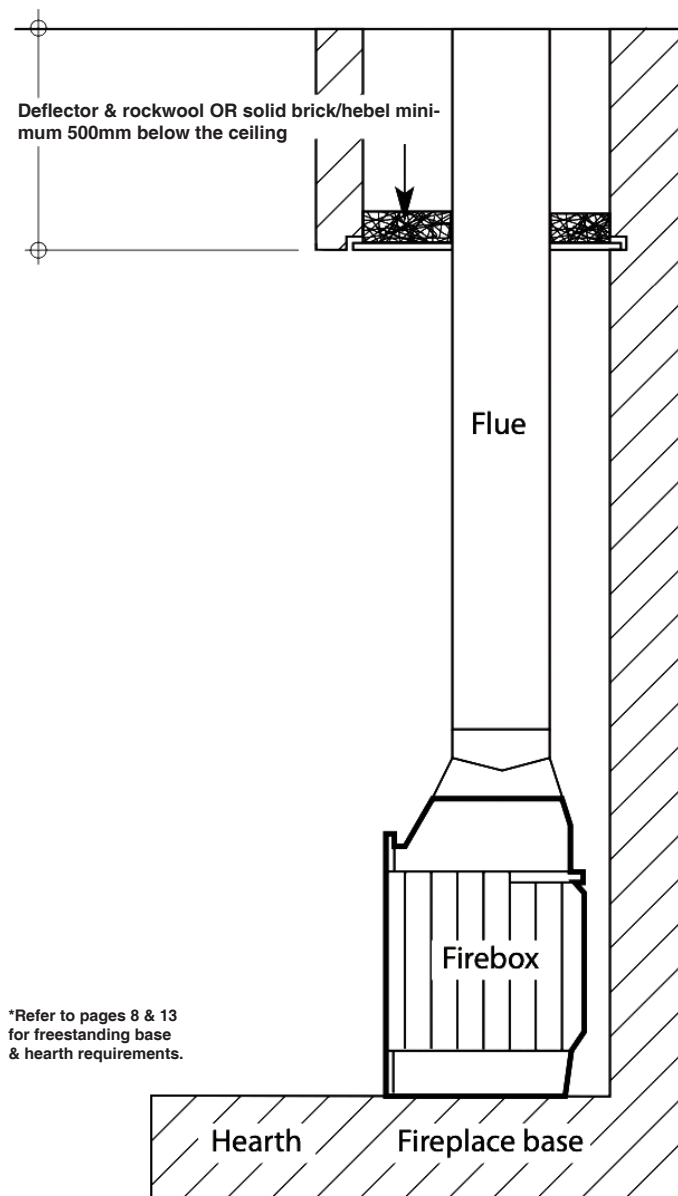

ALCOVE WITH APRON - SIDE VIEW

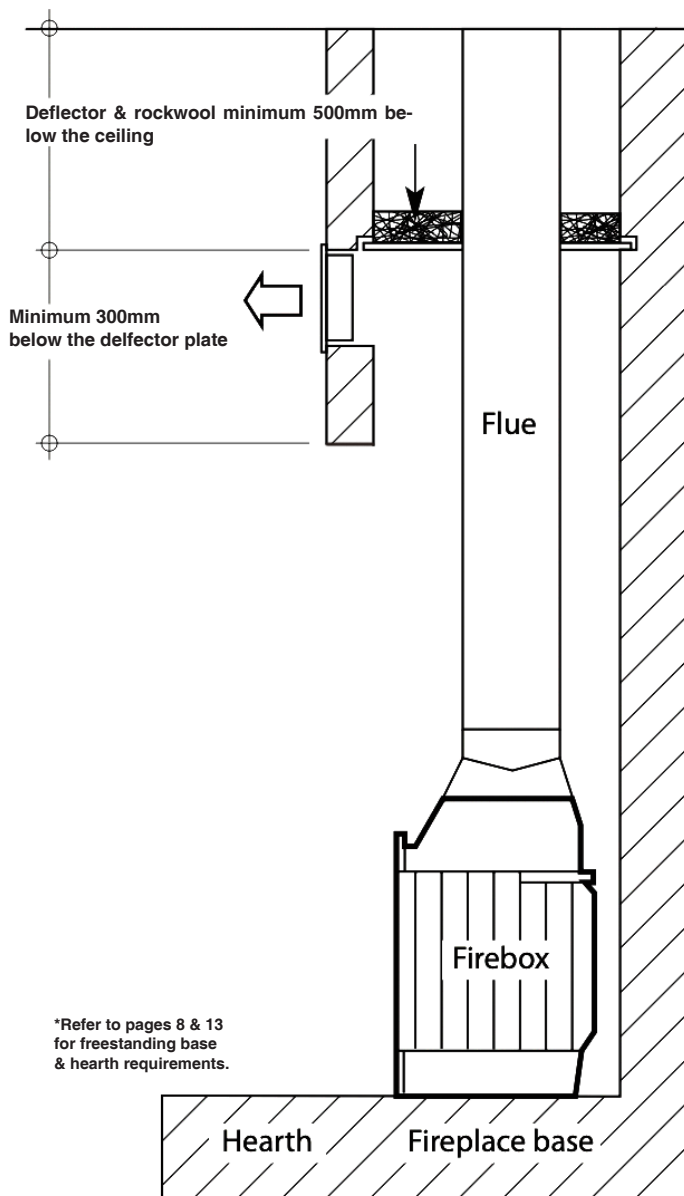

DEFLECTOR PLATE

9" CENTRE DEFLECTOR PLATE

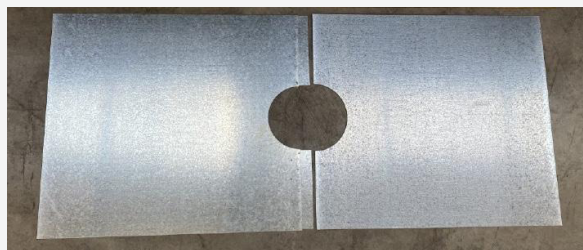

ROCK WOOL BLANKET



- » Deflector to be galvanised metal sheet (1mm minimum) and installed a minimum 500mm below the ceiling
- » The rock wool blanket is to be heat resistant with aluminum foil adhered to one face and installed directly on top of the deflector plate with foil side face down.
- » Ensure the entire plate is tightly secured and sealed to all four edges of the internal cavity with no air gaps
- » Single skin starter flue with gussets is to be installed from the unit to beneath the deflector plate, then the triple skin starter flue (if partial masonry) or remaining single skin flue (if fully masonry) is to be installed above the plate

AIR INLET AND OUTLET GRILLS



- » Ventilation grills consisting of one large grill in front or two smaller grills on either side of the cavity shall be fitted at the bottom of the enclosure for air intake & just below the deflector plate to allow for air outtake
- » All vent material must be non-combustible, metal vents are strongly recommended
- » The vents can be customised to suit the application as long as the minimum sizing is adhered to, refer to page 24 for minimum sizing
- » Air Inlet Clearance: Ensure there is nothing obstructing the front of the vent
- » Air Outlet Clearance: Allow a 600mm clearance in front and 500mm above the vent

MINIMUM INBUILT FLUE COMPONENTS

4.5 METRE 9" PARTIAL MASONRY FLUE KIT



- 1 9" Flue Adaptor*
- 2 9" Starter Flue With Gussets 900mm*
- 3 9"-11"-13" Starter Triple Skin Flue 900mm*
- 4 3 x 9"-11"-13" Triple Skin Flue 900mm*
- 5 9"-13" Cover Cone
- 6 9" Anti Down Draught Cowl

4.5 METRE 9" FULL MASONRY FLUE KIT



- 1 9" Flue Adaptor*
- 2 9" Starter Flue With Gussets 900mm*
- 3 4 x 9" Stainless Steel Flues 900mm
- 4 9"-13" Cover Cone
- 5 9" Anti Down Draught Cowl

*All internal 9" flue must be stainless steel

PARTIAL MASONRY INSTALL OVERVIEW

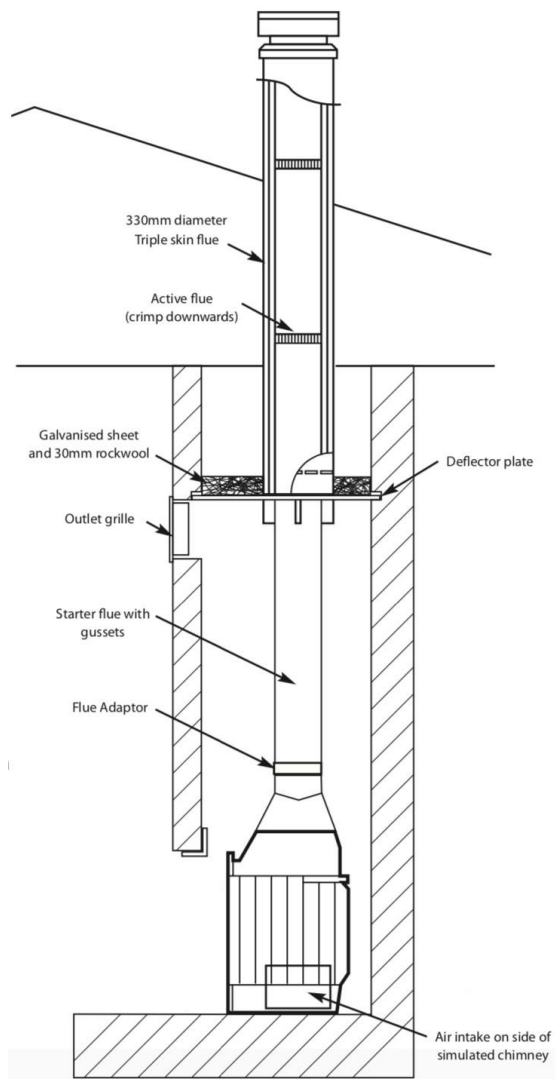

FULL MASONRY INSTALL OVERVIEW

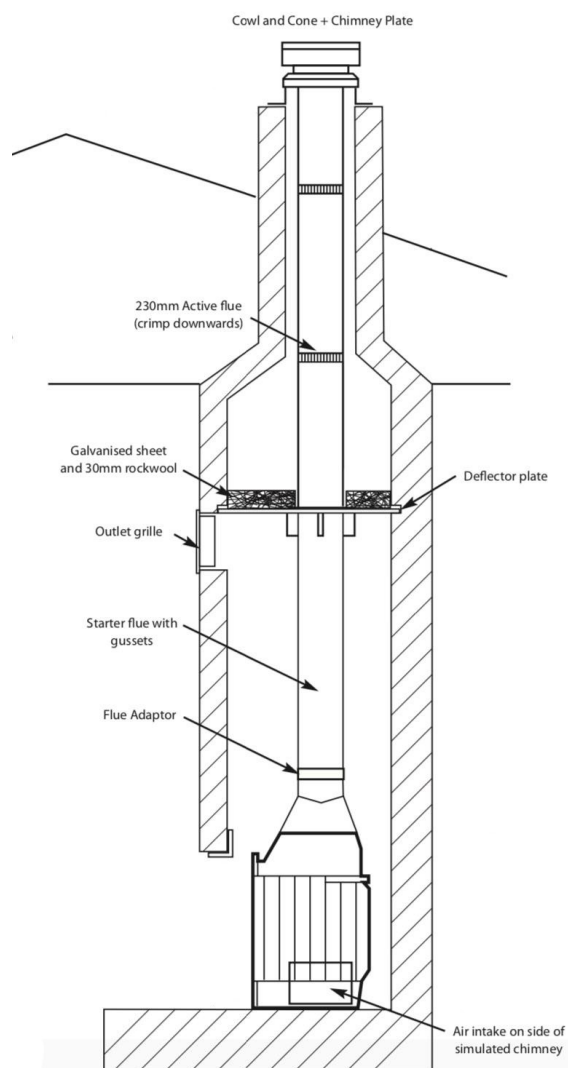

NOTES

5. MECHANISMS & UNIT ASSEMBLY

5.1 MECHANISM GUIDE	30
5.2 PARTS & DAMPER ASSEMBLY	31
5.3 BACK PLATE, BAFFLE PLATE & GRATE ASSEMBLY	32

LOCATION OF MECHANISMS



- 1 Swing door with vitro-ceramic glass
- 2 Removable bolt to measure depression (only if applicable)
- 3 Door handle (use steel rod & glove supplied to operate)
- 4 Primary air adjustment under grate & secondary air adjustment between fire dogs & the glass
- 5 Removable ash tray (open door to access)
- 6 Damper control (use steel rod supplied to operate)

PRIMARY AIR & DAMPER CONTROLS (OPEN & CLOSE)

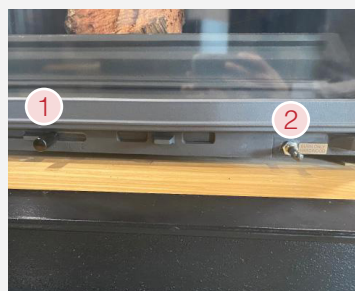

- 1 Close primary air (0. Far left position)
- 2 Push in to close damper

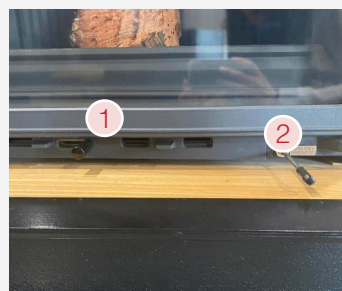

- 1 Open primary air under grate (1. Middle position) & open secondary air between fire dogs & the glass (2. Far right position)
- 2 Pull out to open damper

DOOR OPENING MECHANISMS

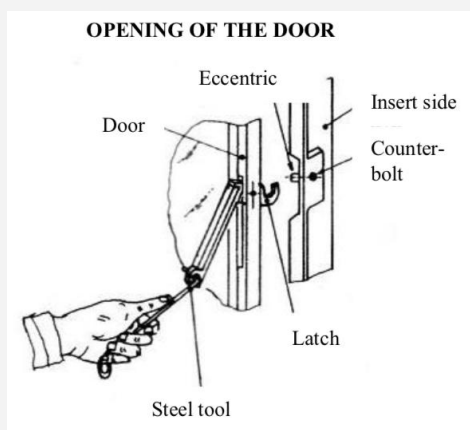

A steel rod as well as gloves have been supplied with your fireplace, ensure these tools are used to operate the opening and closing of the door for ease of use

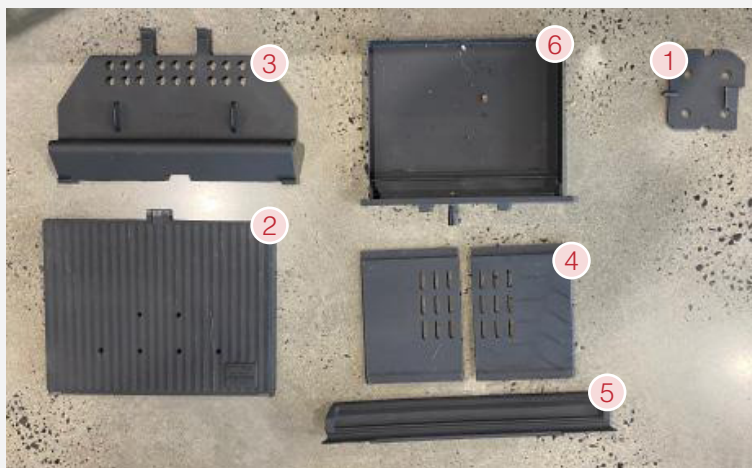

- 1 Damper Plate (also known as Valve Assembly)
- 2 Back Plate
- 3 Baffle
- 4 Grates
- 5 Ash Retainer
- 6 Ash Pan

*For part numbers and the complete parts list refer to page 42.

STEP 1: DAMPER ASSEMBLY (INCLUDING FLEXIBLE ROD)

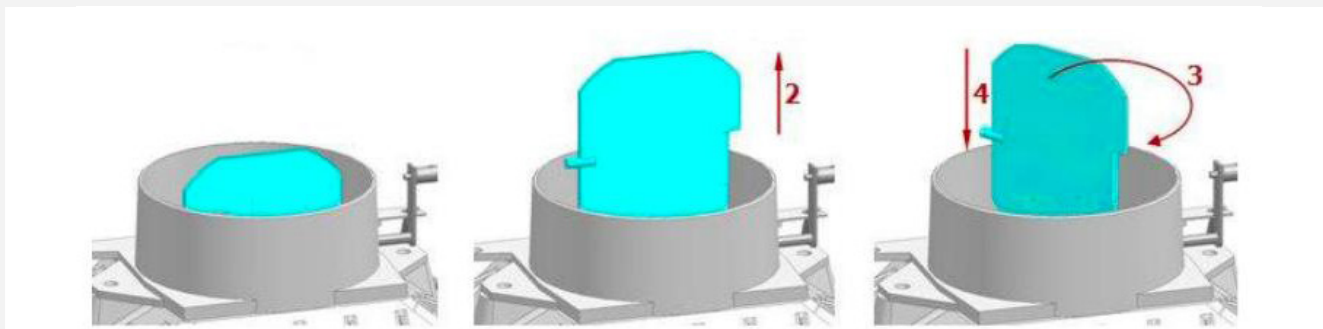

**THIS ASSEMBLY IS DONE PRIOR TO INSTALLING THE FLUE.
IT CAN ALSO BE REMOVED AND RE-ASSEMBLED FOR FLUE SWEEPING FROM INSIDE OF THE FIREBOX.**

See instructions below:

1. Before removing the damper, remove the baffle (take care to hold the decorative back plate of the unit to avoid it falling), then put the damper into the open (vertical) position
2. Raise the damper following the arrow to disengage it from its brackets
3. Turn the damper towards the right hand side
4. Then lower it into the fire place

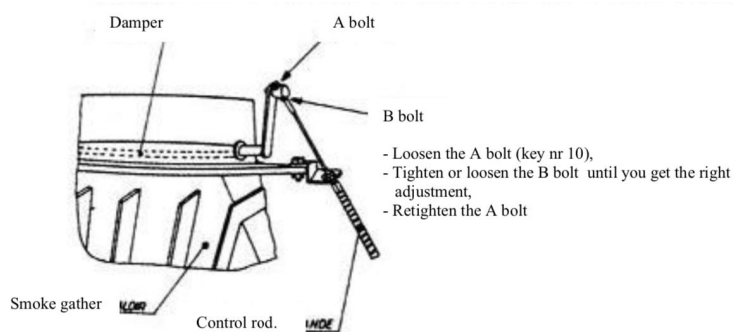

IMPORTANT: IF THE UNIT HAS A DAMPER CABLE THEN IT MUST MAKE REGULAR WIDE CURVES, AVOID BENDING IT IN TWO AT ALL TIMES.

STEP 2: GRATE, ASH RETAINER, BACK PLATE & BAFFLE

ENSURE DAMPER IS FITTED FIRST

1. Fit grate and ash retainer
2. Put the decorative plate between the grooves of the base and the back of the insert.
3. Place the decorative plate down on the back of the insert and hold it (with supporting aid for example)
4. Introduce the baffle as shown on the diagram
5. Put the baffle on the wedges of the back of the unit
6. Put down the baffle on the wedges towards the front

IMPORTANT: ENSURE THE DECORATIVE PLATE IS CORRECTLY SUPPORTED BY THE BAFFLE.

For maintenance or replacing a part, please do the opposite of the instructions here, taking care to hold the decorative plate to avoid it falling down when installing the baffle



LOCATION OF ADJUSTMENTS (IF NECESSARY)

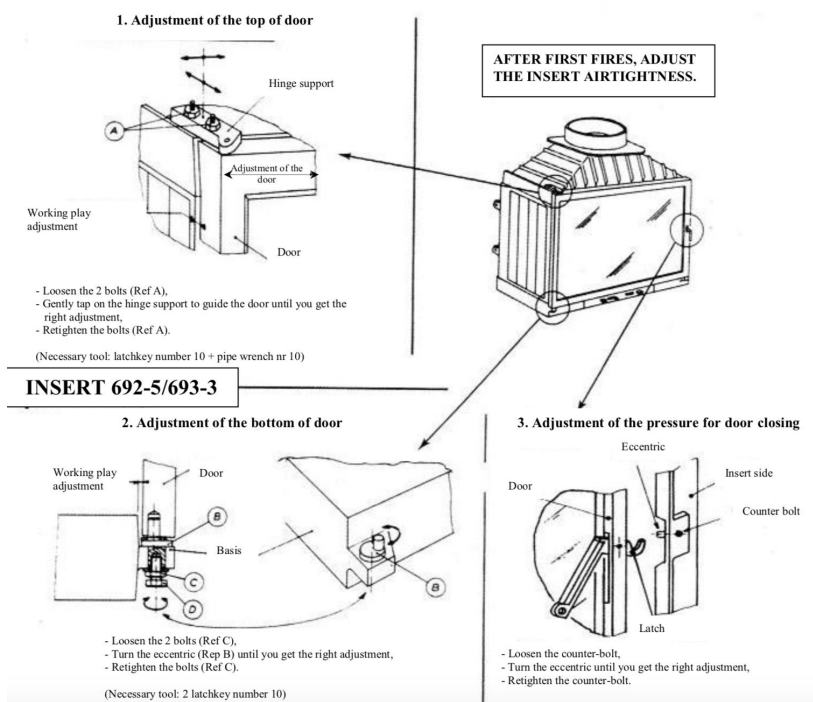

6. OPERATION

6.1 BEFORE FIRST IGNITION	34
6.2 RECOMMENDED FIRE WOOD	35
6.3 HOW TO LIGHT & BURN SAFELY	36 & 37
6.4 WARNING LABELS	38

BEFORE LIGHTING FOR THE FIRST TIME

- » For brick enclosures four weeks drying time should be respected to ensure that moisture evaporates accordingly
- » Once this period has passed, you can light your first fire, with a moderate amount of wood and a reduced opening of the air intake to limit the intensity of the fire, which will allow a progressive rise in temperature within the insert and other elements, to avoid rapid expansion of the materials and thermal shock
- » The first 10 fires should be small fires to finalise the drying process
- » During initial use there may be an odour (not harmful) from the unit caused by surplus paint curing. It is best to ensure adequate and good ventilation during this process. A few additional fires after the drying time may be required to remove this smell

OPEN & CLOSED DOOR OPERATION

- » With the door open: When using the unit with the door open, it is necessary for the damper to be in the open position, to reduce the chances of smoke being blown back. It is NOT recommended to use the unit with the door open for prolonged and continuous periods of time.
- » Never leave the door open unsupervised
- » With the door closed: Opening the damper will ensure that smoke is not blown back out when refueling

FUEL

- » The heat output from a *Cheminées Philippe* fireplace depends mainly on the fuel used
- » Burn hardwood only, refer to page 35 for recommended fire wood
- » Be prepared! It is impossible for a wood merchant to deliver you guaranteed seasoned dry firewood in the middle of a wet winter. The best way to dry wood is to split it and expose the inner core allowing the sun to dry the wood naturally and store your wood for at least 12 months before use
- » **Tip:** Cold wood does not burn as well, so bring your firewood indoors into the warmth a few days before use
- » Do not burn domestic waste, plastic (eg bottles) or plastic derivatives, rubber, oily products (eg oil soaked rags) etc which not only give off an unpleasant odour but will also pollute the environment and can cause hazardous combustion residues in the fireplace and flue which can be harmful to you, your environment and your fireplace

RECOMMENDED FIRE WOODTIME

- » A well installed wood heater burning Australian hardwoods with a moisture range of 15% to 20% will burn more clean and effectively, giving off abundant heat to circulate around your home
- » Anything over 20% and your wood heater will not work efficiently. The energy from the fire will be used to reduce moisture in your wood and not produce heat for your house. It will also produce dangerous amounts of soot very quickly
- » Depending on the humidity of the wood, a 50cm log. 6cm diameter weighs around 1kg, 10cm weighs around 3 kg, 15cm weighs around 7 kg
- » For sustained heat, use large numbers of small logs (eg 6 to 8 logs of 6cm in diameter on a good bed of embers).
- » For a longer lasting fire, use larger diameter logs (eg 3 logs of 13 to 15 cm diameter on a medium bed of embers).
- » **NEVER LOAD MORE THAN 14kg OF WOOD**

MOISTURE CONTENT	OUTCOME
BELOW 15%	Wood very dry and may burn too fast
15%-20%	Wood burns efficiently and economically
20%-25%	Wood burns, but less efficiently than drier option
ABOVE 25%	Wood too wet to burn safely and efficiently

AUSTRALIAN HARDWOOD	% HEAT PER UNIT VOL.	SPLITTING	COALS
GREY BOX	100	Difficult	Many
RED IRON BARK	97	Difficult	Excellent
RED BOX	91	Difficult	Excellent
YELLOW BOX	91	Difficult	Excellent
RED GUM	80	Difficult	Excellent
BLUE GUM	80	Fair	Good
STRINGY BARK	72	Good	Good
NARROW LEAF	72	Good	Good
PEPPERMINT	68	Good	Good
PINE	45	Fair	Poor

MATERIALS REQUIRED TIME

- » Fire lighters
- » Kindling
- » Well seasoned, split hardwood
- » A lighter or match sticks

BEFORE STARTING

- » Ensure the damper, primary and secondary air inlets are fully open
- » Before loading, remove any larger pieces of debris from the previous fire. It is recommended to leave a bed of ash inside the fireplace and to never clean it out completely during the colder months
- » Avoid overloading the unit, wood should only be burnt on the grate itself

LIGHTING OPTION A: TOP DOWN METHOD (RECOMMENDED FOR BEGINNERS)



STEPS

1. Place two layers of cut hardwood in a cross section on top of the fireplace grate. The first layer should be the largest pieces, positioned front to back. The second pieces should be slightly smaller in size and positioned side to side
2. Then follow the same cross section method for the kindling
3. Firestarters should then be evenly positioned between the two layers of kindling on the back, middle and front of the kindling
4. Once the kindling has caught properly close the door and wait for the first hardwood log to light before adjusting the primary and secondary air vents accordingly

LIGHTING OPTION B: TRADITIONAL METHOD



STEPS

1. Place two layers of kindling in a cross section on top of the fireplace grate. The first layer should be positioned front to back. The second layer the pieces should be positioned side to side
2. Place 2-3 pieces of cut hardwood over the kindling to form a pyramid
3. Firestarters should then be evenly positioned between the two layers of kindling on the back, middle and front
4. Once the kindling and hard wood has caught properly close the door adjust the primary and secondary air vents accordingly

- » To ensure maximum performance for your fireplace, it is necessary to keep a close eye on it. It is recommended that refueling is carried out several times rather than overloading the unit
- » Each time more fuel is added ensure a lively fire burns for a short time, so that condensation, which generally forms when fuel is first placed in the fire is evacuated
- » Always have two pieces of wood burning off each other as one log on its own will struggle to stay alight. Therefore for it is important to establish hot coals and a lazy flame for good heat output
- » Using the fireplace for a long time at a very slow burn rate with vents and damper fully closed is not recommended, especially at the start and end of winter and when the temperature rises as this can cause deposits of soot and tar on the window and in the flue
- » Do not use the fireplace with the door and air inlets entirely open at the same time, as well as having an excessive load of wood. This will produce extremely high temperatures inside of the firebox which is likely to damage the cast iron elements of the unit, the connections and the flue
- » Carefully load fire wood into the unit, do not throw or forcefully pack firewood into the unit when reloading. This has the potential to fracture and damage the grate, back and side plates, glass, fire log retainers and over all cast iron internal elements

WARNINGS

- » Never throw water onto the fire to put it out
- » The window pane(s) can reach high temperatures by releasing radiated heat; we advise you not to place sensitive objects within 1500mm proximity
- » Due to extreme temperatures when the unit is lit, ensure adult supervision around young children
- » If your fireplace is equipped with wood storage areas, ensure that they are not obstructed (eg by a door, or by overloading with wood etc) so that air can flow freely. Additionally, do not store easily flammable materials there (eg paper, matches)
- » Caution: in the event of a chimney fire, close the air inlets, close the fireplace door and call the fire brigade

WARNING: ANY MODIFICATION OF THE APPLIANCE THAT HAS NOT BEEN APPROVED IN WRITING BY THE TESTING AUTHORITY IS CONSIDERED AS BREACHING AS/NZS 4013.

WARNING: DO NOT USE FLAMMABLE LIQUIDS OR AEROSOLS TO START OR REKINDLE THE FIRE.

WARNING: DO NOT USE FLAMMABLE LIQUIDS OR AEROSOLS IN THE VICINITY OF THIS APPLIANCE WHEN IT'S OPERATING.

WARNING: DO NOT STORE FUEL WITHIN HEATER INSTALLATION CLEARANCES.

WARNING: WHEN OPERATING THIS APPLIANCE AS AN OPEN FIRE, USE A FIRE SCREEN.

WARNING: OPEN AIR CONTROLS AND DAMPER WHEN FITTED BEFORE OPENING FIRING DOOR.

WARNING: DO NOT BURN WOOD THAT IS PAINTED; OR IS COATED WITH PLASTIC; OR HAS BEEN TREATED WITH ANY CHEMICAL

CAUTION: DO NOT OPERATE THIS APPLIANCE IF GLASS IS CRACKED OR BROKEN.

CAUTION: THIS APPLIANCE SHOULD BE MAINTAINED AND OPERATED AT ALL TIMES IN ACCORDANCE WITH THESE INSTRUCTIONS.

7. MAINTENANCE

7.1 SERVICING GUIDE

40

7.2 TROUBLE SHOOTING

41

7.3 SPARE PARTS

42

SERVICE & ONGOING MAINTENANCE

- » The fireplace should be cleaned at least once a year by a professional, including once during the heating period (winter) to ensure the unit and flue are in good order. The various parts of the unit should be checked, including all door ropes and seals, baffle plate, glass, etc, as it may be necessary to replace these
- » If there are any defects, you must not use the fireplace. Repair or replacement must be carried out before reuse. Ensure that the fitting is carried out by a professional
- » The fireplace is specially designed so that parts can be replaced during routine maintenance
- » Once the heating period is over, clean all the internal cast iron elements, scrape off any soot or tar and brush down all the parts. To facilitate this task, take out all removable parts, (grates, firedog, baffle deflector etc). Reassemble all items, including the damper before reuse
- » After this cleaning, rub all cast iron elements with a suitable *Cheminées Philippe* touch up paint to protect the unit (carry out as often as necessary)
- » Sporadic use perpetuates condensation, which accelerates oxidation. During this period leave air inlets open to allow for circulation of air. Pay particular attention to this in fireplaces which are not used for a continuous period (eg holiday homes) and in coastal areas where the unit and flue are more susceptible to salted air
- » In areas that are subject to high moisture content including but not limited to coastal, rural and green urban spaces, it is recommended that the door is periodically left ajar to avoid a build up of condensation in the firebox
- » For units equipped with a perforated grille on the outside, clean this with a vacuum cleaner to avoid the build up of dust in the perforations which would reduce convection air circulation
- » Regularly empty the ash box to avoid an accumulation of ash which could obstruct and damage the grates. Ashes should be cold and placed in a non-combustible container with a tightly fitting lid and moved outdoors immediately to a location clear of combustible material
- » For equipment with brass accessories or façade, varying degrees of discolouration may occur according to the temperature when in use. When the fireplace is not being used, brass can tarnish through natural oxidation. For this reason, it is necessary to regularly maintain these parts using a copper or brass cleaning product. Avoid staining the brass with the glass cleaning product
- » Clean the glass panel when the window is cold by spraying it with a glass cleaner (AVOID spraying onto any cast iron elements) or as an alternative, use a piece of newspaper dabbed in warm water and then dipped in the ash. Do not use any abrasive cleaning materials on the glass, ie steel wool, abrasive cloths, etc



We recommend to use RUCO glass cleaner. An Australian-made fast-acting formula, that removes soot and creosote from wood heater glass doors.

When the glass is cold, spray the Ruco onto a damp cloth, paper towel or newspaper and use this to wipe the creosote off the glass. For particularly baked on creosote, repeat process.

***Reminder to AVOID spraying the cast iron elements**

OBSERVATION	POTENTIAL SOLUTION
Downdraft; Smoke billowing out of glass	<ul style="list-style-type: none"> - Ensure damper and all air inlets are in the open position several minutes before opening the door - Check there is sufficient fresh air intake into the room (open a door or window to check) - Ensure the flue is cleared of any creosote build up, engage a professional service if required - Using a moisture meter check the moisture content of the wood, refer to pages 34 & 35 - Ensure there are no mechanically operated fans or extractors being used that are in the same vicinity as the fireplace - There may not be enough draw, an extra length of flue is highly recommended and/or fit appropriate cowl - Ensure there is enough fresh air in the room, refer to page 6 - The flue is poorly insulated and the cold outdoor temperatures are causing low flue gas temperatures - Have your fireplace checked by an authorised service agent
Lack of heat; The fire smoulders or goes out	<ul style="list-style-type: none"> - Try and light your fire using cut or smaller pieces of wood - Ensure there is enough fresh air in the room, refer to page 6 - Lack of oxygen in the firebox, ensure inlets are open - Using a moisture meter check the moisture content of the wood, refer to pages 34 & 35
Good fire burning, but low heat output	<ul style="list-style-type: none"> - Ensure glass door is closed when burning - Check that the unit is sufficiently airtight, refer to page 32 for location of adjustments - Ensure the right wood is being used, refer to pages 34 & 35
The window becomes dirty very quickly	<ul style="list-style-type: none"> - Using a moisture meter check the moisture content of the wood, refer to pages 34 & 35 - Avoid too many long, slow burning fires - Check the secondary air in-take is not blocked

PARTS LIST

- » When requesting spare parts or information, please note the serial number which can be found on the identification plate on the base of the unit on the base of the ash pan chamber
- » Only use spare parts, in particular the replacement of glass should only be sourced and supplied by *Cheminées Philippe Australia*
- » Please refer to common parts list on page 31, for all other parts refer to diagram below

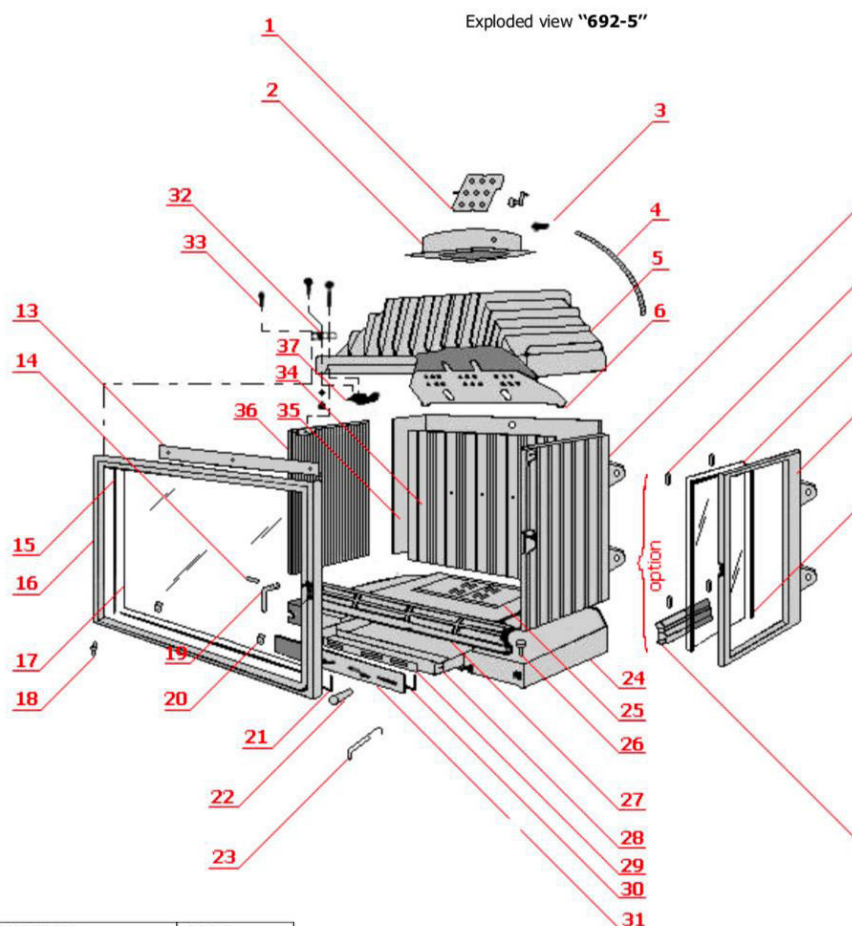

NOT	DESIGNATION	CODE	NOT	DESIGNATION	CODE
1	Valve assembly		16	Door right closure closing on the left	692.3813 B
	- Check valve *	695.3863 B	17	Front glass 641x447 x4	3834
	- articulation mechanism *	3266 C	18	Gond eccentric	3836 F
	- Valve control *	620.66 A	19	Closing handle	5097 .B
	- Joint tip *	3971	20	Clame of window	3152
2	Round outlet Ø230	695.4419C	21	Ceramic braid Ø9 type V	--
3	Cable tie	4470 D	22	Bakelite spindle button	2558
4	Flap control pull *	3882	23	Cold hand steel wire	3859
5	outfall	692.10 A	24	Socket	692.1 A
6	Deflector*	695TX5-6672	25	Fireplace grill * (in 2 parts)	692.3
7	Right side (closing)	692.16 A1	26	pawn	3837 B
8	Clame of window	3152	27	Chenet facade *	692.4 B
9	Side window 387x200.5x4 (following version)	3835	28	Ash tray *	3833
10	Open right side (depending on version)	692.7 .B.1.D	29	Register	692.3394
	Open side (depending on version)	692.7 B	30	Glass braid Ø8 gray	--
11	Wide flat adhesive gasket 8 (U-shaped)	--	31	Ashtray front	695.2TXA
12	Right side chenet * (depending on version)	692.5 B	32	Hinge support	692.12
	Left side chenet * (depending on version)	692.17 B	33	Round head rivet 6x40	--
13	funnel	3831	34	Decor plate *	4878 B
14	Eccentric	3075 B	35	Background	4037
	Eccentric for open dimension	3075 D		Tole air guide	6876
15	Wide flat adhesive gasket 8 (U-shaped)	--	36	Left coast	692.16 A
			37	BBQ leg	692.19

8. WARRANTY

8.1 WARRANTY POLICY & EXTENDED WARRANTY 44

8.2 INSTALLER CHECKLIST FORM 45

WARRANTY

- » The installation guarantee is effective within a framework of compliance with the code of practice, the legislation in force, the installation instructions and the correct use of this fireplace
- » The warranty period begins when the unit has left the warehouse of *Cheminées Philippe Australia*
- » Care will need to be taken with implementation of the various components and connections, the materials used around the fireplace, as well as compliance and conformity with this manual alongside the requirements of AS/NZS 2918:2018
- » This document does not claim to cover all eventualities, or to cover the entirety of the prescriptive legal documentation and does not render exempt the necessity of consulting the latter
- » All weights and dimensions will vary according to the unit model and technical requirements. In order to constantly improve manufacture, we reserve the right to modify our equipment without prior notification
- » *Cheminées Philippe Australia* is free of liability for any damages caused by the replacement of the appliance or its parts, as well as inconvenience expenses, materials to reconstitute the fireplace and/or any delivery costs involved. Incidental or consequential damages are not covered by this warranty
- » All our warranty periods as outlined below are provided on the basis that there is strict compliance with the installation, use and maintenance guide as specified in this manual
- » All parts that come in contact with high temperatures may become deformed by general wear and tear and are therefore guaranteed for one year (as per the table below)
- » **The window panes can resist temperatures of around 750°. So any breakage can only be caused by impact during use or handling and cannot be exchanged under the terms of the warranty
- » During the moulding stage of production, chips may naturally occur in the cast iron. This is not considered a defect and will NOT effect the units performance
- » Warranty does not cover damages originating from incorrect installation, atmospheric conditions including chemical contamination and geographical location (including coastal areas), or over firing of the firebox to extremely high temperatures. These factors can contribute to warping, oxidation, bubbling, discolouration, cracking and/or paint peeling of the firebox and components
- » If the unit is installed outside or in close proximity to coastal environments then any damages sustained by natural elements (rain, sun, salt air, etc) are not covered under warranty
- » This warranty does not cover **rusting** of any of the cast iron components
- » The warranty is non-transferable and stays with the original purchaser, therefore it cannot transfer to a different owner

COMPONENT PARTS	STANDARD WARRANTY	EXTENDED WARRANTY*
Firebox Only	5 Years	+5 Years Total:10 Years
Elevating Door Mechanism & Door Frame	2 Years	
Decorative Back Plates + Sides	1 Year	
Fire Grates	1 Year	
Refractory Elements	1 Year	
Baffles + Dampers	1 Year	
Ashtrays + Ash Retainers	1 Year	
Firedogs + Support Logs	1 Year	
Damper Cables & Sprindle	1 Year	
Ceramic Bricks	1 Year	
All Glass**	None	
Ropes + Seals + Joints + Hinges	None	
Joints + Hinges	None	

Extended Warranty: A five year limited manufacturers warranty is given to all Cheminées Philippe fireboxes only and can be extended to 10 years if the above requirements have been adhered to and a product registration form has been sent to us within 14 days of installation. This can be done online at <https://chemphilaust.com.au/product-registration/>

**For all service and warranty claims, please fill out the request form at
<https://chemphilaust.com.au/service-request/>**

(IT IS MANDATORY TO COMPLETE THIS FORM FOR WARRANTY PURPOSES)

DATE OF INSTALLATION:

Tick

1	Installation of the unit & flue conform to this manual & AS/NZS 2918:2018	
2	All safety clearances and minimum hearth sizes have been abided by	
3	All components (including back & baffle plate) have been fitted correctly	
4	All nuts & bolts to be tightened, seals checked and grease where applicable	
5	A test fire has been lit and the unit draws effectively	
6	All packaging including any flammable material has been removed	
7	The user has been shown the Mechanisms, Operation & Maintenance guide	
8	The user has been advised to cure the firebox initially with 10 small fires	
9	This manual has been left with the owners of this fireplace	
10	A Certificate of Compliance has been given to the owner	

FIRST & LAST NAME OF INSTALLER:

COMPANY NAME (IF APPLICABLE)

CONTACT NUMBER

COMPLIANCE CERTIFICATE #

SERIAL NUMBER OF UNIT (located inside the base of the ashpan chamber)

For warranty please register your fireplace at <https://chemphilaust.com.au/product-registration/>

CHEMINÉES PHILIPPE AUSTRALIA

For more information contact your nearest dealer
or visit www.chemphilaust.com.au